

**1** Venturi Systems -  
City Water Pressure

- Spray-Alls™
- Foamers
- Sanitizers
- Hose Drop Stations
- Conveyor Mate CIP Applicators
- Accessories



# Lafferty

EQUIPMENT MANUFACTURING LLC

**CATALOG 1**

Venturi Systems  
City Water Pressure • 35-125 PSI

# Chemical Application Equipment

[www.LaffertyEquipment.com](http://www.LaffertyEquipment.com)

5614-Oak Grove Road • North Little Rock, AR 72118

Phone: 800-999-2820 / 501-851-2820 • Fax Orders: 800-699-3719

# Production and Environmental Sanitation Equipment

## Critical to Producing the Highest Quality Food Products

---

Regulations, public expectations and competitive pressures require business and industry to maintain clean production areas, machinery and equipment. In today's world, a bacterial or pathogenic food contamination scare can panic people or cripple industries half a world away. Companies that are serious about cleaning invest in the best chemicals and the best chemical application equipment.

Lafferty builds quality into every piece of chemical application equipment – from the precision machining of our injector, foamer and fogger bodies, to the careful selection of heavy-duty components, to the individual testing of every unit. This keeps Lafferty Equipment products working better and longer than any other brand.

Once you experience Lafferty quality and performance, you will know that no other brand can be "just like a Lafferty."

## Venturi Technology Perfected

---

Lafferty Equipment's business is founded on venturi technology. For nearly 40 years, we at Lafferty have been perfecting our product offering through rigorous attention to venturi design and the manufacture of balanced systems, engineered to meet the needs of our customers.

The beauty of using a venturi for chemical application is the simplicity; there are no moving or wearing parts. Lafferty venturis are machined from chemical-resistant, solid, thermoplastics or stainless steel, to ensure long product life despite heavy, daily use or harsh environmental conditions.

*Translating venturi theory into superior performance is the essence of "The Lafferty Difference"*

Lafferty has developed an extensive range of venturi systems — proportioners, sprayers, foamers and foggers — that are designed to suit a wide variety of generalized and specialized applications.

Most Lafferty venturi systems come equipped with 20 different sized metering tips, which are used to control chemical dilution ratios.

Dilution ratios can be set by selecting the appropriate metering tip, using the chart contained in the operating instructions.



## Lafferty's Complete Balanced System Approach

The team at Lafferty Equipment puts more than a century of combined manufacturing and in-the-field experience into the equipment that we offer. Our approach is to provide a complete, balanced system right out of the box for ease of installation and trouble-free performance.

Lafferty Equipment's core product offering is the widest range of chemical application equipment available in the marketplace.

If a standard product does not meet the need, we have many specialized systems not listed in this catalog, which may provide the solution. If not, we will work with you to create a system to meet the client's specific requirements.

Our passionate focus on superior quality, outstanding reliability and attention to detail ensures years of consistent operational performance and peace of mind.

### Focus on Performance

- Dedicated Research and Development team
- Application-specific designs to create integrated balanced systems
- Discharge hoses (lengths and diameters), wands and nozzles carefully selected to ensure optimum system performance
- Machined injector and foamer bodies engineered for their specific, intended use
- Reliable, precision metering options

### Focus on Quality, Reliability and Durability

- Designed to endure heavy usage in industrial settings with minimal maintenance requirements
- Lafferty's proprietary stainless steel and polypropylene components are precision machined on state-of-the-art CNC and traditional machine tools in Lafferty's manufacturing facility in Arkansas.
- Extensive testing of all finished products
- Material selection for optimum chemical and industry compatibility, with all wetted parts chemically resistant
- Stainless steel mounting enclosures for industrial settings or compact Uni-Body™ designs for other commercial applications where stainless steel is not required

### Focus on Service

- Dedicated to superior customer service and support
- Prompt order shipment
- Detailed website and catalog information for equipment selection
- Comprehensive Installation and Operation Instructions



**LAFFERTY SPRAY-ALLS™ AND AIRLESS FOAMERS** are water-driven venturi systems that accurately dilute chemical concentrates to required ratios and project an even spray or high quality airless foam. Suitable for any food preparation area.

Wall mount models feature Lafferty's signature heavy-duty stainless steel mounting enclosure. Portable models feature an all stainless steel cart and the compact Uni-Body™ injector or foamer body.

## SPRAY-ALLS™

REQUIRES: 35-125 PSI WATER

- Lafferty Spray-Alls produce sprays that range from a light to a flooding spray.
- Fan nozzle for quick area coverage

### REQUIREMENTS / SPECIFICATIONS

<b>Water Pressure</b>	<b>35 - 125 PSI</b>	<b>2.4 - 8.6 bar</b>
<b>Water Flow Rate</b>	<b>@ 40 PSI</b>	<b>@ 2.8 bar</b>
W-20HC - Medium Spray	0.6 gpm	2.3 lpm
W-20 - Medium Spray	0.8 gpm	3.0 lpm
W-25 / W-25HC - Medium Spray	1.3 gpm	4.9 lpm
W-50 / W-50HC - Heavy Spray	2.3 gpm	8.7 lpm
W-100 - Flooding Spray	4.0 gpm	15.1 lpm

### Discharge Hose

ID	1/2 in.	12.7 mm
Length	50 ft.	15.2 m

### Includes

- Machined polypropylene injector body
- Color-coded metering tips (20) and metering tip driver
- Stainless steel mounting enclosure
- Discharge hose, stainless steel ball valve, polypropylene wand and matching fan nozzle

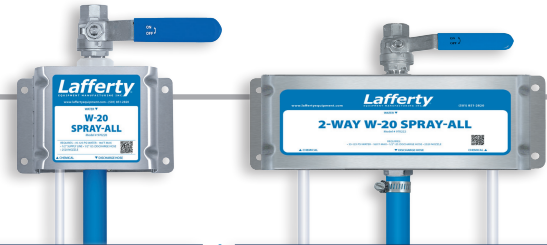

Model #	Description
970220	W-20 Spray-All
970222	2-Way W-20 Spray-All
970225	W-25 Spray-All
970250	W-50 Spray-All
970270	W-100 Spray-All

Model #	Description
<b>High Concentrate Models</b>	
970220HC	W-20HC Spray-All
970225HC	W-25HC Spray-All
970250HC	W-50HC Spray-All



## AIRLESS FOAMERS

REQUIRES: 35-125 PSI WATER

- Lafferty Airless Foamers do not require compressed air, eliminating cost and equipment adjustment issues.
- Foam is created instantly by the venturi airless foam wand.
- Choice of two flow rates provides for quick area coverage for small or large applications.
- Usable foam throw distance of up to 6 ft. for A-25 models and up to 8 ft. for A-50 models — Increased water pressure will increase foam throw.
- Portable models draw chemical from a user-supplied 5 gallon container.

### REQUIREMENTS / SPECIFICATIONS

<b>Water Pressure</b>	<b>35 - 125 PSI</b>	<b>2.4 - 8.6 bar</b>
<b>Water Flow Rate</b>	<b>@ 40 PSI</b>	<b>@ 2.8 bar</b>
A-25	1.3 gpm	4.9 lpm
A-50	2.3 gpm	8.7 lpm

### Discharge Hose

ID	1/2 in.	12.7 mm
Length	50 ft.	15.2 m
Portables	25 ft.	7.6

### Includes

- Machined polypropylene injector body
- Color-coded metering tips (20) and metering tip driver
- Stainless steel mounting enclosure
- Discharge hose, stainless steel ball valve and machined polypropylene airless foam wand
- Stainless steel ball valves
- All stainless steel cart (portable models)



Model #	Description
970525	A-25 Airless Foamer
970527	2-Way A-25 Airless Foamer
975086*	Portable 5 Gallon Uni-Body™ A-25 Airless Foamer
970550	A-50 Airless Foamer
970552	2-Way A-50 Airless Foamer
970550DU	A-50 DU (Dual Chemical Pickup) Airless Foamer
975087*	Portable 5 Gallon Uni-Body™ A-50 Airless Foamer

\*Square jug rack available upon request for portable models



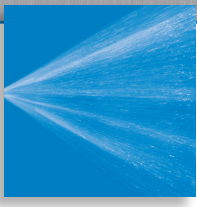

**LAFFERTY SANITIZERS®** are water-driven venturi systems that accurately dilute chemical concentrates to the ratios required for no-rinse applications in food plants, and project the solution onto any surface. The supplied fan nozzle provides quick area coverage.

Wall mount models are offered with Lafferty's signature heavy-duty stainless steel mounting enclosures and polypropylene or stainless steel injectors. Portable models feature heavy-duty stainless steel carts.

## SANITIZERS

REQUIRES: 35-125 PSI WATER

- Lafferty Sanitizers provide the dilution ratios needed for no-rinse applications in food plants.
- Choice of three water flow rates
- Portable models feature all stainless steel cart that holds a user-supplied 5-gallon chemical container.

### Sanitizers for PAA Applications

- Stainless steel bodies
- Stainless steel check valves with Kalrez seals
- PVDF metering tips

### 2-Way Sanitizers

- Choice of two water flow rates
- 2-Way Sanitizers allow alternating between two different chemicals or two different ratios of the same chemical.
  - Wall mount model can be used in either configuration.
  - Portable 5 Gallon model holds one 5-gallon container and is used for alternating between two different ratios of the same chemical

### REQUIREMENTS / SPECIFICATIONS

<b>Water Pressure</b>	<b>35 - 125 PSI</b>	<b>2.4 - 8.6 bar</b>
<b>Water Flow Rate</b>	<b>@ 40 PSI</b>	<b>@ 2.8 bar</b>
315 - Low Flow	4.0 gpm	15.1 lpm
517 - Medium Flow	5.4 gpm	22.4 lpm
1035 - High Flow	9.4 gpm	35.6 lpm
<b>Discharge Hose</b>		
ID		
315	1/2 in.	12.7 mm
517 & 1035	3/4 in.	19.1 mm
Length	50 ft.	15.2 m
Portables	25 ft.	7.6 m

#### Includes

- Machined polypropylene injector body
- Stainless steel mounting enclosure (wall mount models)
- Color-coded metering tips (20)
- Metering tip driver
- Discharge hose, stainless steel ball valve, wand and matching fan nozzle
- Portable models feature all stainless steel carts



Model #	Description
973650	315 Sanitizer
973750	517 Sanitizer
973850	1035 Sanitizer
973945	Portable 517 Sanitizer
Stainless Steel Models for PAA Applications	
973650SS	315 SS Sanitizer
973750SS	517 SS Sanitizer
973850SS	1035 SS Sanitizer



Model #	Description
2-Way Sanitizers	
973752	2-Way 517 Sanitizer
973852	2-Way 1035 Sanitizer
973950	Portable Dual 5 Gallon 2-Way 517 Sanitizer
973955	Portable 5 Gallon, 2-Way 517 Sanitizer

For Portable models this page, specify Round or Square Jug Racks at time of ordering.





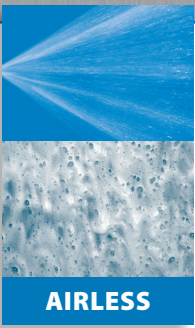

AIRLESS

**LAFFERTY WR-1 SPRAY-ALL™ SYSTEMS** are convenient combination applicators that apply one chemical — as spray or airless foam — and rinse. These water-driven venturi systems accurately dilute chemical concentrates to required ratios and project a spray or high quality, airless foam onto any surface.

Offered with three styles of applicator:

- A Pistol Grip Gun and nozzle comes with the spray/rinse units.
- Lafferty's unique SmartWand™ combines foam and rinse functions into a single hose-end applicator.
- The Pistol Grip Gun Kit features separate foam and rinse applicators with quick disconnect fittings for easy interchanging.

Portable models feature heavy-duty stainless steel carts.

## WR-1 SPRAY-ALLS (CHEMICAL / RINSE)

REQUIRES: 35-125 PSI WATER

- For many uses, including food service facilities
- Apply one chemical — as spray or airless foam — and rinse through a single hose.

### REQUIREMENTS / SPECIFICATIONS

<b>Water Pressure</b>	<b>35 - 125 PSI</b>	<b>2.4 - 8.6 bar</b>
<b>Water Flow Rate</b>	<b>@ 40 PSI</b>	<b>@ 2.8 bar</b>
Airless Foam	1.3 gpm	4.9 lpm
Spray	2.0 gpm	7.6 lpm
Rinse	4.0 gpm	15.1 lpm
<b>Discharge Hose</b>		
ID	1/2 in.	12.7 mm
Length	50 ft.	15.2 m

### Includes

- Machined polypropylene injector bodies
- Water pressure gauge
- Color-coded metering tips (20)
- Metering tip driver
- All stainless steel carts (Portable models)
- Discharge hose assembly and Ball Valve with...
  - Pistol Grip Gun (stainless steel body with insulated grip), fan nozzle and nozzle protector (975123 and 975186)
  - SmartWand™ (975125 and 975187)
  - Pistol Grip Gun Kit: Insulated grip; stainless steel gun body, fittings and quick disconnects; fan nozzle and nozzle protector; machined polypropylene airless foam wand (975127 and 975188)



Model #	Description
975123	WR-1 Spray / Rinse w/Pistol Grip Gun
975125	WR-1 Foam / Rinse w/SmartWand
975127	WR-1 Foam / Rinse w/Pistol Grip Gun Kit
975186	Portable WR-1 Spray / Rinse w/Pistol Grip Gun
975187	Portable WR-1 Foam / Rinse w/SmartWand
975188	Portable WR-1 Foam / Rinse w/Pistol Grip Gun Kit



Pistol Grip Spray/Rinse/Sanitize Gun & Nozzle

Pistol Grip Gun Kit - Stainless steel gun body, quick disconnects and fittings

Lafferty SmartWand

Rotate SmartWand™ 180° to switch from foam to spray or rinse

• **MICRO FLOW WR-2 SPRAY-ALL SYSTEMS** — Very low flow units for many uses — food service, veterinary, animal washing, etc.

• **WR-3 SYSTEMS** —  
For applying 3 chemicals from a single unit through a single hose



For details see  
Catalog 12: Supermarket / Deli / Small Area Cleaning Systems

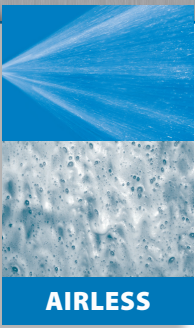

**LAFFERTY WR-2 SPRAY-ALL™ SYSTEMS** are convenient combination applicators that apply two chemicals as airless foam or spray — for cleaning and sanitizing — and rinse. These water-driven venturi systems accurately dilute chemical concentrates to required ratios and project a uniform spray or high quality, airless foam onto any surface.

Offered with three styles of applicator:

- A Pistol Grip Gun and nozzle comes with the spray/rinse/sanitize units.
- Lafferty's unique SmartWand™ combines all three functions —foam, rinse, sanitize— into a single hose-end applicator.
- The Pistol Grip Gun Kit features separate foam and rinse applicators with quick disconnect fittings for easy interchanging.

Portable models feature heavy-duty stainless steel carts.

## WR-2 SPRAY-ALLS – FOAM / RINSE / SANITIZE (SPRAY)

REQUIRES: 35-125 PSI WATER, CHEMICAL CONCENTRATES

- Ideal for supermarkets, delis and food service facilities
- Foam, rinse and sanitize through a single hose or spray, rinse and sanitize through a single hose

### REQUIREMENTS / SPECIFICATIONS

<b>Water Pressure</b>	<b>35 - 125 PSI</b>	<b>2.4 - 8.6 bar</b>
<b>Water Flow Rate</b>	<b>@ 40 PSI</b>	<b>@ 2.8 bar</b>
Airless Foam / Spray	1.3 gpm	4.9 lpm
Rinse	4.0 gpm	15.1 lpm
Sanitize	2.0 gpm	7.6 lpm
<b>Discharge Hose</b>		
ID	1/2 in.	12.7 mm
Length	50 ft.	15.2 m

### Includes

- Machined polypropylene injector bodies
- Water pressure gauge
- Color-coded metering tips (20) and tip driver
- All stainless steel carts (Portable models)
- Discharge hose assembly and Ball Valve with...
  - Pistol Grip Gun (stainless steel body with insulated grip), fan nozzle and nozzle protector (975223 and 975296)
  - SmartWand™ (975225 and 975297)
  - Pistol Grip Gun Kit: Pistol grip gun (as above) and quick disconnects; machined polypropylene airless foam wand (975227 and 975298)

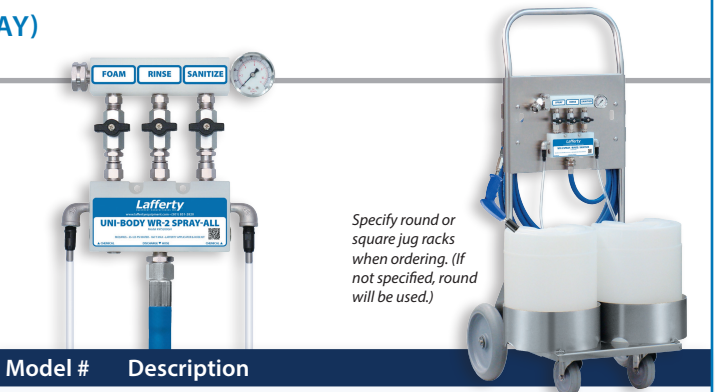

Specify round or square jug racks when ordering. (If not specified, round will be used.)

Model #	Description
975223	WR-2 Spray / Rinse / Sanitize w/Pistol Grip Gun
975225	WR-2 Foam / Rinse / Sanitize w/SmartWand
975227	WR-2 Foam / Rinse / Sanitize w/Pistol Grip Gun Kit
975296	Portable WR-2 Spray / Rinse / Sanitize w/Pistol Grip Gun
975297	Portable WR-2 Foam / Rinse / Sanitize w/SmartWand
975298	Portable WR-2 Foam / Rinse / Sanitize w/Pistol Grip Gun Kit

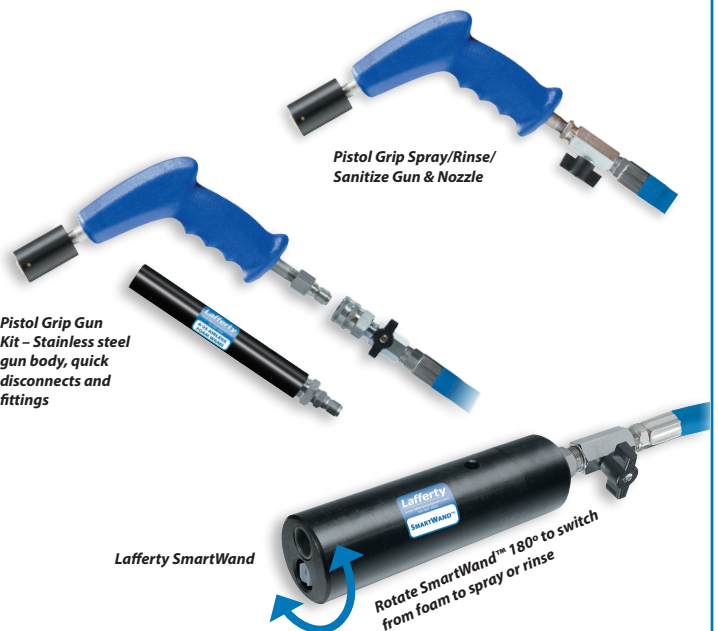

• **MICRO FLOW WR-2 SPRAY-ALL SYSTEMS** — Very low flow units for many uses — food service, veterinary, animal washing, etc.

• **WR-3 SYSTEMS** — For applying 3 chemicals from a single unit through a single hose



For details see  
Catalog 12: Supermarket / Deli / Small Area Cleaning Systems

## AIR ASSISTED

**LAFFERTY FOAMERS** are water-driven, air-assisted venturi systems that accurately dilute chemical concentrates to required ratios and project high quality foam onto any surface, providing for superior cleaning and visual assurance of complete coverage. A wide range of foam volumes and throw distances are available and the optimum model to use will be determined by the application and desired coverage speed.

Wall mount models feature Lafferty's signature heavy-duty stainless steel mounting enclosures/brackets and polypropylene or stainless steel bodies. Portable models include heavy-duty stainless steel carts.

## LV FOAMER

REQUIRES: 35-125 PSI WATER, COMPRESSED AIR

- Low volume output for precise foaming applications, such as small pieces of process equipment, small or tight areas or where over spray will create a problem.
- Minimal water usage.
- Usable foam throw distance of up to 9 feet
- Covers up to 500 ft.<sup>2</sup> (46.5 m<sup>2</sup>) in 4½ minutes

### REQUIREMENTS / SPECIFICATIONS

<b>Compressed Air</b>	<b>up to 3 cfm</b>	<b>up to 85 lpm</b>
<b>Water Pressure</b>	<b>35 - 125 PSI</b>	<b>2.4 - 8.6 bar</b>
<b>Water Flow Rate</b>	<b>@ 40 PSI</b>	<b>@ 2.8 bar</b>
	0.7 gpm	2.5 lpm
<b>Discharge Hose</b>		
ID	3/4 in.	19.1 mm
Length	40 ft.	12.2 m

### Includes

- Machined foamer body (PP or SS)
- Stainless steel mounting enclosure
- Water and air pressure gauges
- Color-coded metering tips (20)
- Metering tip driver
- Discharge hose, ball valve, polypropylene foam wand and matching fan nozzle

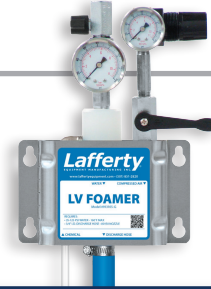

Model #	Description
913105-G	LV Foamer
913115-G	LVSS Foamer



Foam wand with stainless steel ball valve and fan nozzle



Upgrade Option for LV, Ultimate and LC units listed this and next page: Stainless Steel Wand upgrade when ordering with unit. Request item # 536603-X.

## ULTIMATE FOAMERS

REQUIRES: 35-125 PSI WATER, COMPRESSED AIR

- Medium volume output for all foaming applications in food plant sanitation
- Will foam harder-to-foam chemicals and perform well when water pressure is marginal.
- Usable foam throw distance of up to 12 feet (Equipped with a 50 ft. hose.)
- Covers up to 500 ft.<sup>2</sup> (46.5 m<sup>2</sup>) in 2 minutes

### REQUIREMENTS / SPECIFICATIONS

<b>Compressed Air</b>	<b>up to 3 cfm</b>	<b>up to 85 lpm</b>
<b>Water Pressure</b>	<b>35 - 125 PSI</b>	<b>2.4 - 8.6 bar</b>
<b>Water Flow Rate</b>	<b>@ 40 PSI</b>	<b>@ 2.8 bar</b>
	1.3 gpm	4.9 lpm
<b>Discharge Hose</b>		
ID	3/4 in.	19.1 mm
Length	50 ft.	15.2 m

### Includes

- Machined polypropylene or stainless steel foamer body
- Stainless steel mounting bracket
- Water and air pressure gauges
- Color-coded metering tips (20)
- Metering tip driver
- Discharge hose, ball valve, polypropylene foam wand and matching fan nozzle



Model #	Description
914105-G	Ultimate Foamer
914107-G	2-Way Ultimate Foamer
914115-G	Ultimate SS Foamer



Foam wand with stainless steel ball valve and fan nozzle



## LC FOAMERS

REQUIRES: 35-125 PSI WATER, COMPRESSED AIR

- Medium volume output for all foaming applications
- Usable foam throw distance of up to 12 feet
- Covers up to 500 ft.<sup>2</sup> (46.5 m<sup>2</sup>) in 2 minutes
- LCHC (High Concentrate) model available for tough cleaning jobs
- Dual Pickup (DU) models draw two chemicals at the same time as with, for example, a detergent and a foaming agent.
- 2-Way models draw two chemicals separately or simultaneously or can draw two different dilutions of the same chemical for different cleaning requirements.
- Lock Box models feature a lockable, stainless steel enclosure

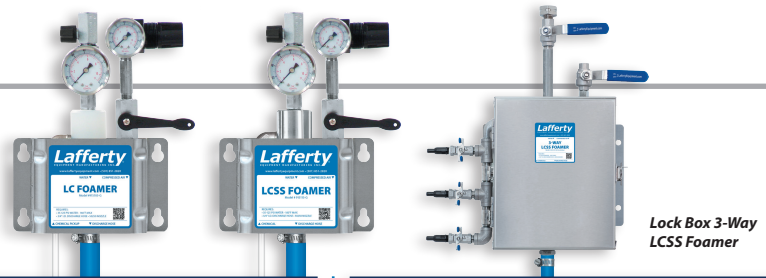

Model #	Description
915105-G	LC Foamer
915106-G*	LCHC Foamer
<i>*High Concentrate Unit</i>	
915115-G	LCSS Foamer
<b>Dual Pickup and 2-Way Models</b>	
915105DU-G	LCDU Foamer
915107-G	2-Way LC Foamer

Model #	Description
<b>Lock Box Models</b>	
915105-LB	Lock Box LC Foamer
915117-LB2	Lock Box 2-Way LCSS Foamer
915117-LB3	Lock Box 3-Way LCSS Foamer



Foam wand with stainless steel ball valve and fan nozzle

### REQUIREMENTS / SPECIFICATIONS

<b>Compressed Air</b>	<b>up to 3 cfm</b>	<b>up to 85 lpm</b>
<b>Water Pressure</b>	<b>35 - 125 PSI</b>	<b>2.4 - 8.6 bar</b>
<b>Water Flow Rate</b>	<b>@ 40 PSI</b>	<b>@ 2.8 bar</b>
	1.3 gpm	4.9 lpm

#### Discharge Hose

ID	3/4 in.	19.1 mm
Length	40 ft.	12.2 m

#### Includes

- Machined polypropylene or stainless steel foamer body
- Stainless steel mounting enclosure/bracket

- Water and air pressure gauges
- Color-coded metering tips (20)
- Metering tip driver
- Discharge hose, ball valve, polypropylene foam wand and matching fan nozzle

## LIBERTY PRV LC FOAMERS

REQUIRES: 20-80 PSI WATER, COMPRESSED AIR

- Liberty PRV LC Foamers connect to standard water pressure from 20 to 80 PSI and use a pressure reducing valve to lower the incoming water pressure before an air pump boosts the water pressure and maintains consistent 60 PSI output for the venturi LC foamer.
- Overcome problems associated with very low or widely fluctuating water pressure. — Great for locations that utilize well water.
- Medium volume output for all foaming applications
- Usable foam throw distance of up to 12 feet
- Covers up to 500 ft.<sup>2</sup> (46.5 m<sup>2</sup>) in 2 minutes
- 2-Way and 3-Way models available to draw two or three chemicals separately or simultaneously or provide different dilutions of the same chemical for different cleaning requirements.
- Lockable, stainless steel cabinet protects components, including the venturi foamer body.

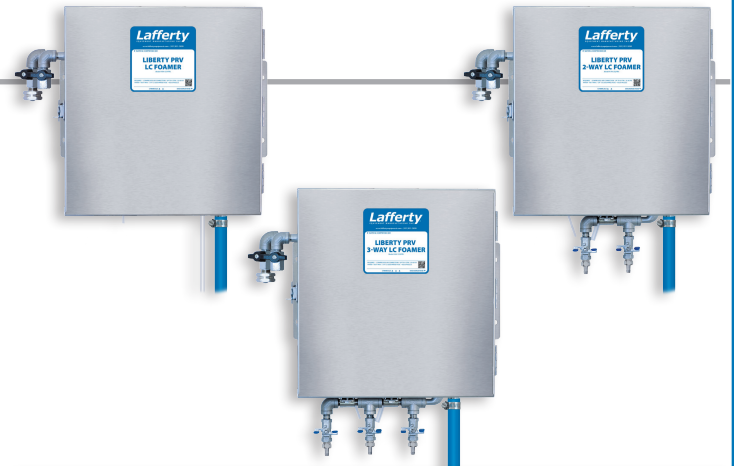

Model #	Description
941351PRV	Liberty PRV LC Foamer
941352PRV	Liberty PRV 2-Way LC Foamer
941353PRV	Liberty PRV 3-Way LC Foamer



Foam wand with stainless steel ball valve and fan nozzle

### REQUIREMENTS / SPECIFICATIONS

<b>Compressed Air</b>	<b>up to 6 cfm</b>	<b>up to 170 lpm</b>
<b>Water Pressure</b>	<b>35 - 125 PSI</b>	<b>2.4 - 8.6 bar</b>
<b>Water Flow Rate</b>	<b>@ 60 PSI</b>	<b>@ 4.1 bar</b>
	1.64 gpm	6.2 lpm

#### Discharge Hose

ID	3/4 in.	19.1 mm
Length	50 ft.	15.2 m

#### Includes

- Lockable, stainless steel enclosure
- Air inlet ball valve and regulator/filter
- Water inlet ball valve and regulator
- Flojet 1/4" AODD pump (Santoprene diaphragm)
- Machined polypropylene LC Foamer body
- Stainless steel chemical ball valves
- 20 color-coded precision metering tips to set dilution ratios
- 50' discharge hose, stainless steel ball valve, polypropylene foam wand & stainless steel fan nozzle

## HV AND HVHC FOAMERS

REQUIRES: 35-125 PSI WATER, COMPRESSED AIR

- High volume output for foaming large surface areas quickly
- Usable foam throw distance of up to 15 feet with standard fan nozzle; up to 20 feet with optional 0° nozzle
- Covers up to 500 ft.<sup>2</sup> (46.5 m<sup>2</sup>) in 1 minute
- HVHC (High Concentrate) model available for tough cleaning jobs

### REQUIREMENTS / SPECIFICATIONS

<b>Compressed Air</b>	<b>up to 5 cfm</b>	<b>up to 142 lpm</b>
<b>Water Pressure</b>	<b>35 - 125 PSI</b>	<b>2.4 - 8.6 bar</b>
<b>Water Flow Rate</b>	<b>@ 40 PSI</b>	<b>@ 2.8 bar</b>
	4.0 gpm	15.1 lpm
<b>Discharge Hose</b>		
ID	1 in.	25.4 mm
Length	50 ft.	15.2 m

### Includes

- Machined polypropylene foamer body
- Machined stainless steel foamer body (916115SS)
- Water and air pressure gauges
- Stainless steel mounting bracket
- Color-coded metering tips (20)
- Metering tip driver
- Discharge hose, ball valve, polypropylene foam wand and matching fan nozzle.

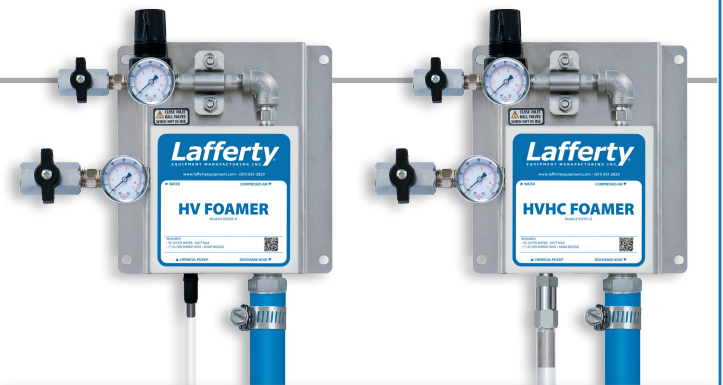

Model #	Description
916105-G	HV Foamer
916105-LB	Lock Box HV Foamer
916115-G	HVHC Foamer
916115SS	HVHCSS Foamer



Foam wand with stainless steel ball valve & fan nozzle (0° nozzle optional for extended foam throw distance)

## SUPER HV FOAMER

REQUIRES: 30-150 PSI WATER, COMPRESSED AIR

- Super high volume output for foaming very large surface areas and reaching high ceilings
- Usable foam throw distance of up to 45 feet
- Covers up to 500 ft.<sup>2</sup> (46.5 m<sup>2</sup>) in 40 seconds

### REQUIREMENTS / SPECIFICATIONS

<b>Compressed Air</b>	<b>up to 12 cfm</b>	<b>up to 340 lpm</b>
<b>Water Pressure</b>	<b>30 - 150 PSI</b>	<b>2.1 - 10.3 bar</b>
<b>Water Flow Rate</b>	<b>@ 40 PSI</b>	<b>@ 3.4 bar</b>
	9.8 gpm	37.1 lpm
<b>Discharge Hose</b>		
ID	1 1/2 in.	38.1 mm
Length	50 ft.	15.2 m

### Includes

- Machined polypropylene foamer body
- Stainless steel mounting bracket
- Water and air pressure gauges
- Stainless steel ball valves
- Color coded metering tips for up to 21 dilution ratios
- Metering tip driver

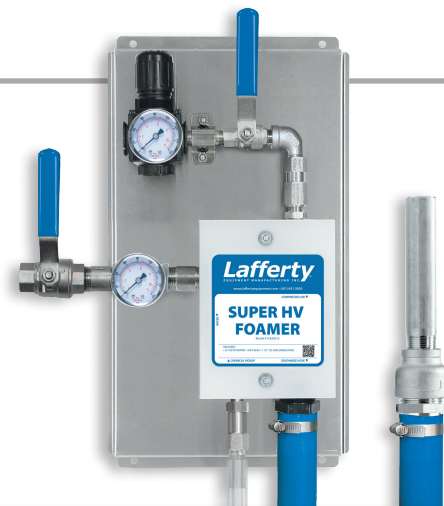

Discharge hose and open flow foam nozzle

Model #	Description
916205-G	Super HV Foamer

## PORTABLE HV AND SUPER HV FOAMERS

REQUIRES: 30-125 PSI WATER, COMPRESSED AIR

- Lafferty Portable Foamers allow foam cleaning in areas inaccessible to fixed mounted units.
- Choice of either high or super high volume output
- Choice of 20- or 60-gallon models or a 16-gallon model with an integrated, gasoline powered air compressor

### HV Foamer (high volume):

- Usable foam throw distance of up to 15 feet with standard fan nozzle; up to 20 feet with optional 0° nozzle.

- Covers up to 500 ft.<sup>2</sup> (46.5 m<sup>2</sup>) in 1 minute

### Super HV Foamer (super high volume):

- Usable foam throw distance of up to 45 feet
- Covers up to 500 ft.<sup>2</sup> (46.5 m<sup>2</sup>) in 40 seconds

## REQUIREMENTS / SPECIFICATIONS

### Compressed Air

HV	<b>up to 5 cfm</b>	<b>up to 142 lpm</b>
Super HV	<b>up to 12 cfm</b>	<b>up to 340 lpm</b>

### Water Pressure

HV	<b>35 - 125 PSI</b>	<b>2.4 - 8.6 bar</b>
Super HV	<b>30 - 150 PSI</b>	<b>2.1 - 10.3 bar</b>

### Water Flow Rate

	<b>@ 40 PSI</b>	<b>@ 2.8 bar</b>
HV	4.0 gpm	15.1 lpm
Super HV	9.8 gpm	37.1 lpm

### Discharge Hose

ID		
HV	1 in.	25.4 mm
Super HV	1 1/2 in.	38.1 mm
Length		
HV	40 ft.	12.2 m
Super HV & 916875	50 ft.	15.2 m

### Includes

- Machined polypropylene foamer body
- Polyethylene tanks
- All stainless steel carts
- Color-coded metering tips (20)
- Metering tip driver
- Discharge hose, stainless steel ball valve, polypropylene foam wand and matching nozzle (HV)
- Discharge hose and open flow, stainless steel foam nozzle (Super HV)



916820



916860



916960

Model #	Description
916820*	Portable 20 Gallon HV Foamer
916860	Portable 60 Gallon HV Foamer
916860HC**	Portable 60 Gallon HVHC Foamer
916875	Portable Gas Powered 16 Gallon HV Foamer
916960	Portable 60 Gallon Super HV Foamer

\*Color options available, see below.

\*\*High Concentrate (HC)



916875

The Portable Gas Powered 16 Gallon HV Foamer is a high volume foam applicator featuring a 4-wheel, all stainless steel cart assembly, an integrated gas powered Honda air compressor and a 16 gallon chemical concentrate tank.



50400 fan nozzle (HV models) — 0° nozzle optional



Open flow foam nozzle (Super HV)



\* Color options available for any 20-gallon portable model





## AIR ASSISTED

**LAFFERTY UNI-BODY™ FOAMERS** are water-driven venturi systems that accurately dilute chemical concentrates to required ratios and use compressed air to create and project rich, clinging foam. A wide range of foam volumes and throw distances are available and the optimum model to use will be determined by the application and desired coverage speed.

Offered in Lafferty's compact Uni-Body design for easy mounting virtually anywhere. A wide range of portable models feature heavy-duty stainless steel carts and a variety of tank capacities.

## UNI-BODY™ FOAMER

REQUIRES: 35-125 PSI WATER, COMPRESSED AIR

- Low to Medium volume output for all foaming applications
- Usable foam throw distance of up to 14 feet (LV 9'; LC 12'; MV 14')
- Air and water gauges

### REQUIREMENTS / SPECIFICATIONS

#### Compressed Air

<b>LV Uni-Body</b>	<b>up to 1.25 cfm</b>	<b>up to 35.4 lpm</b>
<b>LC Uni-Body</b>	<b>up to 3 cfm</b>	<b>up to 85 lpm</b>
<b>MV Uni-Body</b>	<b>up to 4 cfm</b>	<b>up to 113 lpm</b>

**Water Pressure**      **35 - 125 PSI**      **2.4 - 8.6 bar**

**Water Flow Rate**      **@ 40 PSI**      **@ 2.8 bar**

LV Uni-Body	0.65 gpm	2.5 lpm
LC Uni-Body	1.3 gpm	4.9 lpm
MV Uni-Body	2.45 gpm	9.3 lpm

#### Discharge Hose

ID	3/4 in.	19.1 mm
Length	40 ft.	12.2 m

#### Includes

- Machined polypropylene foamer body
- Water and air pressure gauges
- Color-coded metering tips for up to 21 dilution ratios and metering tip driver
- Discharge hose, stainless steel ball valve, polypropylene foam wand and matching fan nozzle



Model #	Description
975545-G	Uni-Body™ LV Foamer
975555-G	Uni-Body™ LC Foamer
975560-G	Uni-Body™ MV Foamer



Polypropylene foam wand with stainless steel ball valve and fan nozzle



Upgrade Option for Uni-Body Foamers listed above: Stainless Steel Wand upgrade when ordering with unit. Request item # 536603-X.

## UNI-BODY™ BRUSH FOAMERS

REQUIRES: 50-125 PSI WATER, COMPRESSED AIR

- Very low volume, balanced output provides ideal foam volume at the brush head
- Soft nylon bristles clean efficiently and gently
- Not intended for use on surfaces / equipment that contact food

### REQUIREMENTS / SPECIFICATIONS

**Compressed Air**      **up to 0.5 cfm**      **up to 14 lpm**

**Water Pressure**      **50 - 125 PSI**      **3.4 - 8.6 bar**

**Water Flow Rate**      **@ 50 PSI**      **@ 3.4 bar**

0.35 gpm	1.3 lpm
----------	---------

#### Discharge Hose

ID	1/2 in.	12.7 mm
Length	50 ft.	15.2 m

#### Includes

- Machined polypropylene foamer body with compact Uni-Body design
- Water and air pressure gauges
- Color-coded metering tips (10)
- Metering tip driver
- Discharge hose, ball valve, 44 inch handle and foam brush head



Model #	Description
975525	Uni-Body™ Soft Brush Foamer

# PORTABLE UNI-BODY™ FOAMERS

REQUIRES: 30-125 PSI WATER, COMPRESSED AIR

- Lafferty Portable Uni-Body™ Foamers allow foam cleaning in areas inaccessible to fixed mounted units.
- Medium volume output
  - Usable foam throw distance of up to 12 feet
  - Covers up to 500 ft.<sup>2</sup> (46.5 m<sup>2</sup>) in 2 minutes
- Choice of 2-wheel or 4-wheel cart models
- Choice of 5 or 20-gallon models

## REQUIREMENTS / SPECIFICATIONS

<b>Compressed Air</b>	<b>up to 3 cfm</b>	<b>up to 85 lpm</b>
<b>Water Pressure</b>	<b>35 - 125 PSI</b>	<b>2.4 - 8.6 bar</b>
<b>Water Flow Rate</b>	<b>@ 40 PSI</b>	<b>@ 2.8 bar</b>
	1.3 gpm	4.9 lpm
<b>Discharge Hose</b>		
ID	3/4 in.	19.1 mm
Length	25 ft.	7.6 m

## Includes

- Machined polypropylene foamer body
- Polyethylene tank on 20-gallon model (5-gallon models hold user-supplied chemical pail/jug.)
- All stainless steel carts
- Color-coded metering tips (20)
- Metering tip driver
- Discharge hose, stainless steel ball valve, polypropylene foam wand and matching nozzle



For 5 Gallon models, specify round or square jug racks at time of ordering.



Model #	Description
975805	Portable 4-Wheel 5 Gallon Uni-Body™ LC Foamer
975805-C	Portable 5 Gallon Uni-Body™ LC Foamer w/Compressor
975806	Portable Dual 5 Gallon Uni-Body™ 2-Way LC Foamer
975818*	Portable 2-Wheel 20 Gallon Uni-Body™ LC Foamer



Upgrade Option for Units listed this page: Stainless Steel Wand upgrade when ordering with unit. Request item # 536603-X.



\* Color options available for any 20-gallon portable model



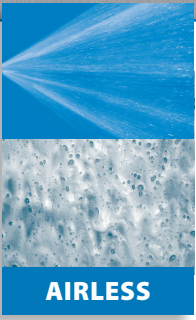

**LAFFERTY AIRLESS HOSE DROP STATIONS** are convenient combination systems offered as Rinse / Sanitize, Rinse / Airless Foam, Sanitize / Airless Foam and Sanitize / Rinse / Airless Foam configurations.

Lafferty Airless Hose Drop Stations are water-driven, venturi systems that accurately dilute chemical concentrates to required ratios and project a sanitizing spray or high quality, wet foam onto any surface, without the need for compressed air. Rinse models include a clear water rinse functionality.

Wall mount models are offered with Lafferty's signature heavy-duty stainless steel mounting enclosures.

## RINSE / 517 SANITIZE HOSE DROP STATION

REQUIRES: 35-125 PSI WATER

- Lafferty Rinse / Sanitize Hose Drop Stations are convenient combination systems that apply chemical as a sanitizing spray, and rinse.
- Dilutes concentrated sanitizers to the lean ratios required for no-rinse applications in food plants
- Sanitizer solution is projected as a flooding spray
- Lafferty's unique 4-hole stainless steel rinse nozzle provides a powerful, high performance rinse.

### REQUIREMENTS / SPECIFICATIONS

<b>Water Pressure</b>	<b>35 - 125 PSI</b>	<b>2.4 - 8.6 bar</b>
<b>Water Flow Rate</b>	<b>@ 40 PSI</b>	<b>@ 2.8 bar</b>
Sanitizer	5.4 gpm	20.4 lpm
Rinse	7.2 gpm	27.3 lpm
<b>Discharge Hose</b>		
ID		
Sanitize	3/4 in.	19.1 mm
Rinse	3/4 in.	19.1 mm
Length	50 ft.	15.2 m

### Includes

- Machined polypropylene injector body
- Stainless steel Y strainer
- Stainless steel mounting enclosure
- Stainless steel ball valves
- Color-coded metering tips (20)
- Metering tip driver
- Two discharge hose assemblies:
  - Sanitize: Hose with stainless steel ball valve, polypropylene wand and matching stainless steel nozzle
  - Rinse: Hose with stainless steel ball valve and Lafferty's powerful 4-hole stainless steel rinse nozzle

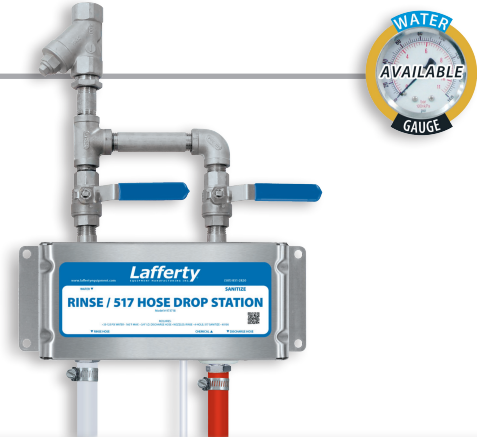

Model #	Description
973718	Rinse / 517 Sanitize Hose Drop Station
<b>Option</b>	
336348	3/4" Water Pressure Gauge Assembly



Sanitize discharge hose assembly



Upgrade Option for Sanitize wand: Stainless Steel Wand upgrade when ordering with unit. Request item # 536603-X.

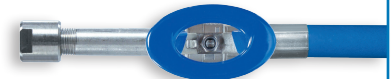

Rinse hose assembly with Lafferty's 4-hole rinse nozzle



## RINSE / AIRLESS FOAM HOSE DROP STATIONS

REQUIRES: 35-125 PSI WATER

- Lafferty Rinse / Airless Foam Hose Drop Stations are convenient combination systems that apply chemical as foam, and rinse.
- Lafferty's unique 4-hole stainless steel rinse nozzle provides a powerful, high performance rinse.
- Medium volume output for all foaming applications. Foam is created instantly by the venturi airless foam wand.
- Usable foam throw distance of up to 6 feet
- Covers up to 500 ft.<sup>2</sup> (46.5 m<sup>2</sup>) in 2 minutes

### REQUIREMENTS / SPECIFICATIONS (see below)

#### Includes

- Machined polypropylene injector body
- Stainless steel Y strainer
- Stainless steel mounting enclosure
- Stainless steel ball valves
- Color-coded metering tips (20) and metering tip driver
- Two discharge hose assemblies:
  - Foam: Hose with stainless steel ball valve and machined polypropylene airless foam wand.
  - Rinse: Hose with stainless steel ball valve and Lafferty's powerful 4-hole stainless steel rinse nozzle

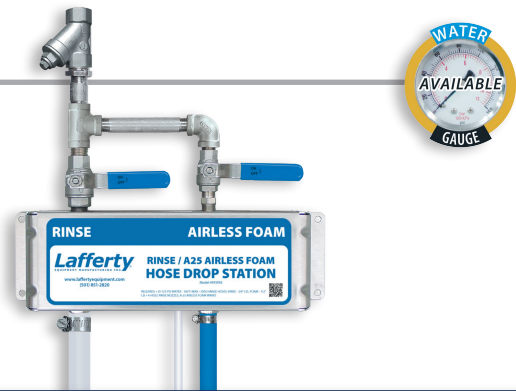

Model #	Description
915918	Rinse / A-25 Airless Foam Hose Drop Station
<b>Option</b>	
336348	3/4" Water Pressure Gauge Assembly

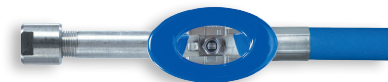

Rinse hose assembly with Lafferty's 4-hole rinse nozzle (Foam discharge hose assembly shown below.)

## SANITIZE / AIRLESS FOAM HOSE DROP STATIONS

REQUIRES: 35-125 PSI WATER

- Lafferty Sanitize / Airless Foam Hose Drop Stations are convenient combination systems that apply one chemical as foam and a second chemical as a sanitizing spray.
- 517 Sanitizers provide the dilution ratios required for no-rinse applications in food plants.
- Airless Foamers provide medium volume output for all foaming applications. Foam is created instantly by the venturi airless foam wand
- Usable foam throw distance of up to 6 feet
- Covers up to 500 ft.<sup>2</sup> (46.5 m<sup>2</sup>) in 2 minutes

#### Includes

- Machined polypropylene injector bodies
- Stainless steel Y strainer and stainless steel ball valves
- Stainless steel mounting enclosure
- Color-coded metering tips (20) and metering tip driver
- Two discharge hose assemblies:
  - Sanitize: Red hose with stainless steel ball valve, polypropylene wand and matching stainless steel nozzle
  - Foam: Blue hose with stainless steel ball valve and machined polypropylene airless foam wand

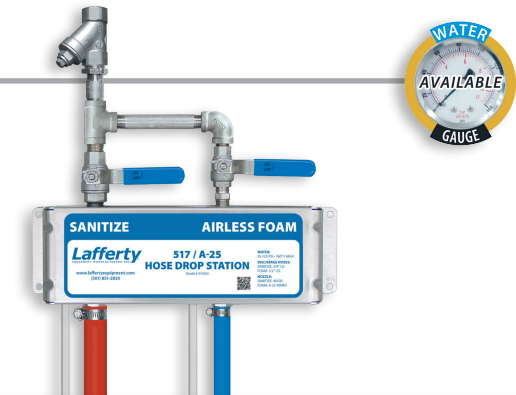

Model #	Description
915920	517 Sanitize / A-25 Airless Foam HDS
<b>Option</b>	
336348	3/4" Water Pressure Gauge Assembly



Sanitize discharge hose assembly



Upgrade Option for Sanitize wand: Stainless Steel Wand upgrade when ordering with unit. Request item # 536603-X.



Foam discharge hose assembly

### REQUIREMENTS / SPECIFICATIONS

<b>Water Pressure</b>	<b>35 - 125 PSI</b>	<b>2.4 - 8.6 bar</b>
<b>Water Flow Rate</b>	<b>@ 40 PSI</b>	<b>@ 2.8 bar</b>
Rinse (915918)	7.2 gpm	27.3 lpm
Sanitize (915920)	5.4 gpm	22.4 lpm
Airless Foam	1.3 gpm	4.9 lpm
<b>Discharge Hose</b>		
ID		
Rinse	3/4 in.	19.1 mm
Sanitize	3/4 in.	19.1 mm
Airless Foam	1/2 in.	12.7 mm
Length	50 ft.	15.2 m

# SANITIZE / RINSE / AIRLESS FOAM HOSE DROP STATIONS

REQUIRES: 35-125 PSI WATER

- Lafferty Sanitize/Rinse/Foam Airless Hose Drop Stations are convenient combination systems that apply one chemical as foam and apply a second chemical as a sanitizing spray, and rinse.
- 517 Sanitizers provide the dilution ratios required for no-rinse applications in food plants.
- Lafferty's unique 4-hole stainless steel rinse nozzle provides a powerful, high performance rinse.
- Airless Foamers provide medium volume output for all foaming applications. Foam is created instantly in the venturi airless foam wand.
- Usable foam throw of up to 6 feet, covering up to 500 ft.<sup>2</sup> (46.5 m<sup>2</sup>) in 2 minutes.

## REQUIREMENTS / SPECIFICATIONS

<b>Water Pressure</b>	<b>35 - 125 PSI</b>	<b>2.4 - 8.6 bar</b>
<b>Water Flow Rate</b>	<b>@ 40 PSI</b>	<b>@ 2.8 bar</b>
Sanitize	5.4 gpm	22.4 lpm
Airless Foam	1.3 gpm	4.9 lpm
Rinse	7.2 gpm	27.3 lpm

### Discharge Hose

ID		
Sanitize/Rinse	3/4 in.	19.1 mm
Foam	1/2 in.	12.7 mm
Length	50 ft.	15.2 m
Portable	40 ft.	12.2 m

### Wall Mount Model Includes:

- Machined polypropylene injector bodies
- Stainless steel Y strainer
- Stainless steel mounting enclosure and stainless steel ball valves
- Color-coded metering tips (20)
- Three discharge hose assemblies :
  - Sanitize: Red hose with stainless steel ball valve, polypropylene wand and matching fan nozzle
  - Rinse: Blue hose with stainless steel ball valve and Lafferty's powerful 4-hole stainless steel rinse nozzle
  - Foam: Blue hose with stainless steel ball valve and machined polypropylene airless foam wand

### Portable Model Includes:

- All stainless steel 4-wheel cart with integrated hose rack
- Non-marking tires with stainless steel swivel casters
- 2 stainless steel, round, 5 gallon jug racks (square optional)
- Machined polypropylene foamer and sanitizer bodies
- Stainless steel inlet and discharge ball valves
- 20 color-coded precision metering tips to set dilution ratios
- Metering tip driver
- Quick connect 40' discharge hose
- Quick connect, stainless steel, airless foam wand
- Quick connect, powerful, stainless steel 4-hole nozzle
- Quick connect sanitize wand and fan nozzle

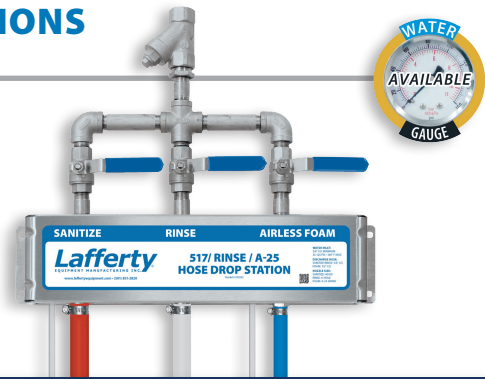

Model #	Description
915925	517 Sanitize / Rinse / A-25 Airless Foam HDS
915955	Portable 517 Sanitize / Rinse / A-25 Airless Foam HDS
<b>Option</b>	
336348	3/4" Water Pressure Gauge Assembly

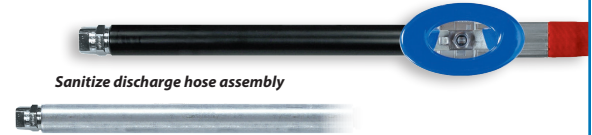

Sanitize discharge hose assembly

Upgrade Option for Sanitize wand: Stainless Steel Wand upgrade when ordering with unit. Request item # 536603-X.



Foam discharge hose assembly



Rinse hose assembly with Lafferty's 4-hole rinse nozzle



**For Portable models, specify Round or Square Jug Racks at time of ordering.**



**LAFFERTY HOSE DROP STATIONS** are convenient combination systems offered as Rinse / Foam, Sanitize / Foam and Sanitize / Rinse / Foam configurations.

Lafferty Hose Drop Stations are water-driven, air-assisted venturi systems that accurately dilute chemical concentrates to required ratios and project a sanitizing spray or high quality foam onto any surface.

Wall mount models are offered with Lafferty's signature heavy-duty stainless steel mounting enclosures and portable models feature heavy-duty stainless steel carts.

## RINSE/FOAM HOSE DROP STATIONS

REQUIRES: 35-125 PSI WATER, COMPRESSED AIR

- Lafferty Rinse / Foam Hose Drop Stations are convenient combination systems that apply one chemical as foam, and rinse.
- Lafferty's unique 4-hole stainless steel rinse nozzle provides a powerful, high performance rinse.
- Ultimate and LC Foamers provide medium volume output for all foaming applications.
- Ultimate Foamers will foam harder-to-foam chemicals, will perform well when water pressure is marginal, and are equipped with a 50 ft. hose. (LC Foamers are equipped with a 40 ft. hose.)
- Usable foam throw distance of up to 12 feet
- Covers up to 500 ft.<sup>2</sup> (46.5 m<sup>2</sup>) in under 2½ minutes
- Portable model features a stainless steel cart that holds a user-supplied 5-gallon chemical container.

### REQUIREMENTS / SPECIFICATIONS

<b>Compressed Air</b>	<b>up to 3 cfm</b>	<b>up to 85 lpm</b>
<b>Water Pressure</b>	<b>35 - 125 PSI</b>	<b>2.4 - 8.6 bar</b>
<b>Water Flow Rate</b>	<b>@ 40 PSI</b>	<b>@ 2.8 bar</b>
Foam	1.3 gpm	4.9 lpm
Rinse	7.2 gpm	27.3 lpm
<b>Discharge Hoses</b>		
ID	3/4 in.	19.1 mm
Length		
Ultimate Foam / Rinse	50 ft.	15.2 m
LC Foam / Rinse	40 ft.	12.2 m

### Includes

- Machined polypropylene foamer body
- Stainless steel Y strainer
- Stainless steel mounting enclosure
- Color-coded metering tips (20)
- Metering tip driver
- Two discharge hose assemblies:

Foam: Hose with stainless steel ball valve, foam wand and matching fan nozzle

Rinse: Hose with stainless steel ball valve and Lafferty's powerful 4-hole stainless steel rinse nozzle

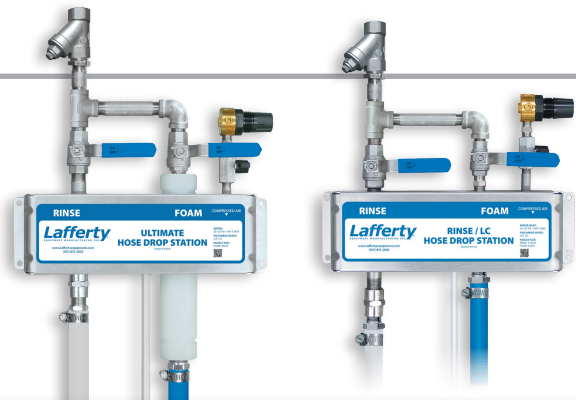

Model #	Description
914118	Rinse / Ultimate Foam HDS
915118	Rinse / LC Foam HDS
915840	Portable Rinse / LC Foam HDS
<b>Options</b>	
336322	Air Gauge Upgrade (installed)
336348	3/4" Water Pressure Gauge Assembly



Sanitize discharge hose assembly



Upgrade Option for Sanitize wand: Stainless Steel Wand upgrade when ordering with unit. Request item # 536603-X.



Rinse hose assembly with Lafferty's 4-hole rinse nozzle



**For Portable models, specify Round or Square Jug Racks at time of ordering.**



Tank not included

### Foam / Rinse / Foam Model

Model #	Description
915143	1-Hose LC Foam/Rinse/LC Foam HDS

- A single hose is equipped with QD sockets at each end and a stainless steel discharge ball valve at one end.
- Both the stainless steel foam wand and the 4-hole rinse nozzle assembly are equipped with QD plugs
- The hose connects to either foam discharge plug or the rinse plug at the unit and the corresponding foam wand or rinse assembly connects to the discharge end of the hose.
- Requirements/Specifications are the same as for # 915118

## FOAM / FOAM HOSE DROP STATIONS

REQUIRES: 35-125 PSI WATER, COMPRESSED AIR

- Lafferty Foam / Foam Hose Drop Stations will apply either two chemicals or two dilution ratios of the same chemical as high quality foam.
- LC and Ultimate Foamers provide medium volume output for all foaming applications.
- Ultimate Foamers will foam harder-to-foam chemicals and will perform well when water pressure is marginal
- Usable foam throw distance of up to 12 feet
- Covers up to 500 ft.<sup>2</sup> (46.5 m<sup>2</sup>) in under 2½ minutes

### REQUIREMENTS / SPECIFICATIONS

<b>Compressed Air</b>	<b>up to 3 cfm</b>	<b>up to 85 lpm</b>
<b>Water Pressure</b>	<b>35 - 125 PSI</b>	<b>2.4 - 8.6 bar</b>
<b>Water Flow Rate</b>	<b>@ 40 PSI</b>	<b>@ 2.8 bar</b>
Ultimate & LC Foamers	1.3 gpm	4.9 lpm
<b>Discharge Hoses</b>		
ID	3/4 in.	19.1 mm
Length	50 ft.	15.2 m

### Includes

- Machined polypropylene foamer bodies
- Stainless steel Y strainer
- Stainless steel mounting enclosure (wall mount models)
- Color-coded metering tips (20) and tip driver
- Two discharge hoses (red and blue), each with stainless steel ball valve, polypropylene wand and matching nozzle

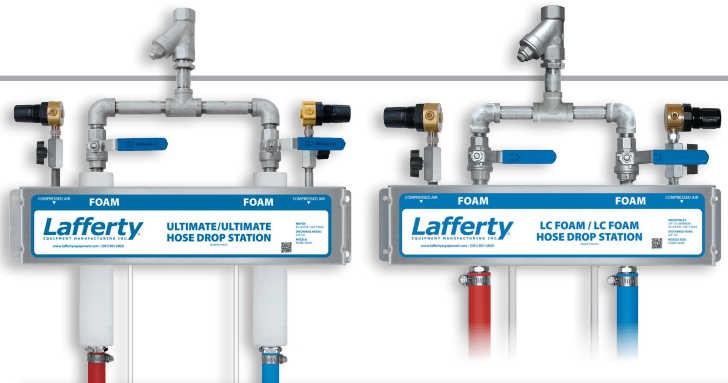

Model #	Description
914135	Ultimate Foam / Ultimate Foam HDS
915135	LC Foam / LC Foam HDS
<b>Options (All models, this page)</b>	
336322	Air Gauge Upgrade (installed / each)
336348	3/4" Water Pressure Gauge Assembly



Foam discharge hose assembly

## LOW VOLUME FOAM HOSE DROP STATIONS: SPRAY / FOAM

REQUIRES: 35-125 PSI WATER, COMPRESSED AIR

- These units feature a low volume foamer and are combination applicators for applying one chemical as foam and another as a chemical spray for cleaning or sanitizing.
- LV Foamers provide low volume output for precise foaming applications, such as small pieces of process equipment, small or tight areas or where over spray will create a problem.
- Usable foam throw distance of up to 9 feet
- The overall low flow rate of the W-20 Spray / LV Foam Hose Drop Station makes it great for foaming and spraying virtually any sized area or object slowly and completely.

### REQUIREMENTS / SPECIFICATIONS

<b>Compressed Air</b>	<b>up to 3 cfm</b>	<b>up to 85 lpm</b>
<b>Water Pressure</b>	<b>35 - 125 PSI</b>	<b>2.4 - 8.6 bar</b>
<b>Water Flow Rate</b>	<b>@ 40 PSI</b>	<b>@ 2.8 bar</b>
W-20 Spray	0.8 gpm	3.0 lpm
LV Foamer	0.6 gpm	2.3 lpm
<b>Discharge Hoses</b>		
ID		
Foam	3/4 in.	19.1 mm
W-20 Spray	1/2 in.	12.7 mm
Length	50 ft.	15.2 m

### Includes

- Machined polypropylene foamer bodies
- Stainless steel Y strainer
- Stainless steel mounting enclosure
- Color-coded metering tips for up to 21 dilution ratios and metering tip driver
- Two discharge hoses: Red spray hose with stainless steel ball valve, spray wand and matching nozzle; and blue foam hose with stainless steel ball valve, polypropylene wand and matching nozzle

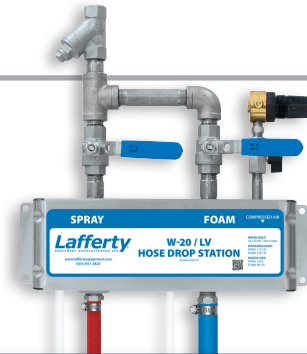

Model #	Description
913119	W-20 Spray / LV Foam HDS





# 517 SANITIZE / FOAM AND SANITIZE / RINSE / FOAM HOSE DROP STATIONS

REQUIRES: 35-125 PSI WATER, COMPRESSED AIR

- Lafferty Sanitize / Foam and Sanitize/Rinse/Foam Hose Drop Stations are convenient combination systems that apply one chemical as foam and a second chemical as a sanitizing spray.
- Rinse models incorporate a clear water rinse function into the unit.
- 517 Sanitizers use a medium water flow rate — 5.4 gpm — to provide the dilution ratios required for no-rinse applications in food plants.
- Ultimate and LC Foamers provide medium volume output for all foaming applications.
- LV Foamers provide low volume output for precise foaming applications, such as small pieces of process equipment, small or tight areas or where over spray will create a problem.
- Ultimate Foamers will foam harder-to-foam chemicals, will perform well when water pressure is marginal, and are equipped with a 50 ft. hose. (LC Foamers are equipped with a 40 ft. hose.)
- Usable foam throw distance of up to 12 feet
- Covers up to 500 ft.<sup>2</sup> (46.5 m<sup>2</sup>) in under 2½ minutes
- Portable model features a stainless steel cart that holds two, user-supplied 5-gallon chemical containers.

## REQUIREMENTS / SPECIFICATIONS

<b>Compressed Air</b>	<b>up to 3 cfm</b>	<b>up to 85 lpm</b>
<b>Water Pressure</b>	<b>35 - 125 PSI</b>	<b>2.4 - 8.6 bar</b>
<b>Water Flow Rate</b>	<b>@ 40 PSI</b>	<b>@ 2.8 bar</b>
517 Sanitizer	5.4 gpm	22.4 lpm
Foam		
LV Foamer	0.7 gpm	2.5 lpm
Ultimate & LC Foamers	1.3 gpm	4.9 lpm
Rinse	7.2 gpm	27.3 lpm
<b>Discharge Hoses</b>		
ID	3/4 in.	19.1 mm
Length ( <i>applies to all hoses with unit</i> )		
Ultimate Foam models	50 ft.	15.2 m
LC Foam & LV Foam models	40 ft.	12.2 m



## Includes

- Machined polypropylene sanitizer and foamer bodies
- Stainless steel sanitizer and foamer bodies (SS models)
- Stainless steel Y strainer and stainless steel ball valves
- Stainless steel mounting enclosure
- Color-coded metering tips (20) and metering tip driver
- Two or three discharge hose assemblies, depending on unit:

**Sanitize:** Hose with stainless steel ball valve, spray wand and matching fan nozzle

**Foam:** Hose with stainless steel ball valve, foam wand and matching fan nozzle

**Rinse:** Hose with stainless steel ball valve and Lafferty's powerful 4-hole stainless steel rinse nozzle



**For Portable models, specify Round or Square Jug Racks at time of ordering.**

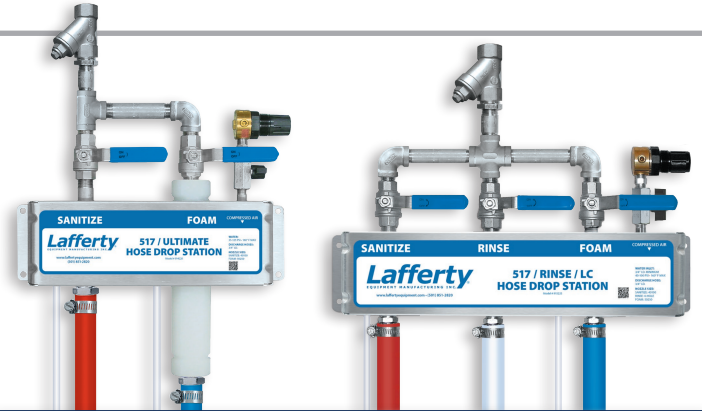

Model #	Description
<b>Sanitize / Foam Models</b>	
914220	517 Sanitize / Ultimate Foam HDS
914220SS†	517 SS Sanitize / Ultimate SS Foam HDS
915220	517 Sanitize / LC Foam HDS
915220-LA‡	Lock-Away 517 Sanitize / LC Foam HDS
915825	Portable 517 Sanitize / LC Foam HDS
<b>Sanitize / Rinse / Foam Models</b>	
913125	517 Sanitize / Rinse / LV Foam HDS
913125SS†	517 SS Sanitize / Rinse / LVSS Foam HDS
914225	517 Sanitize / Rinse / Ultimate Foam HDS
915225	517 Sanitize / Rinse / LC Foam HDS
915225SS†	517 SS Sanitize / Rinse / LCSS Foam HDS
915828	Portable 517 Sanitize / Rinse / LC Foam HDS
<b>One Hose Models with QDs</b>	
913131	1- Hose 517 Sanitize / Rinse / LV Foam HDS
914131	1- Hose 517 Sanitize / Rinse / Ultimate Foam HDS

*With quick disconnect / connect fittings, one hose attaches, as needed, to sanitize/rinse/foam nipple and the corresponding wand attaches to hose. Otherwise, requirements/specifications are the same as for 913125 and 914225, respectively.*

† SS = Includes stainless steel sanitizer and foamer bodies

‡ LA = Includes full stainless steel enclosure. Lockable with your padlock to prevent unauthorized use or tampering with settings.



Sanitize discharge hose assembly



Foam discharge hose assembly



Rinse hose assembly with Lafferty's 4-hole rinse nozzle



Upgrade Option for Sanitize or Foam wands: Stainless Steel Wand upgrade when ordering with unit. Specify upgrade separately for each wand desired. Request item # 536603-X.

## 1035 SANITIZE / FOAM HOSE DROP STATIONS

REQUIRES: 35-125 PSI WATER, COMPRESSED AIR

- Lafferty Sanitize / Foam Hose Drop Stations are convenient combination systems that apply one chemical as foam and a second chemical as a sanitizing spray.
- Quick disconnects allow one hose to be used for both foaming and sanitizing.
- 1035 Sanitizers provide the dilution ratios required for no-rinse applications in food plants.
- Ultimate and LC Foamers provide medium volume output for all foaming applications.
- Ultimate Foamers will foam harder-to-foam chemicals, will perform well when water pressure is marginal, and are equipped with a 50 ft. hose. (LC Foamers are equipped with a 40 ft. hose.)
- Usable foam throw distance of up to 12 feet
- Covers up to 500 ft.<sup>2</sup> (46.5 m<sup>2</sup>) in under 2½ minutes
- Portable model features a stainless steel cart that holds two, user-supplied 5-gallon chemical containers.

### REQUIREMENTS / SPECIFICATIONS

<b>Compressed Air</b>	<b>up to 3 cfm</b>	<b>up to 85 lpm</b>
<b>Water Pressure</b>	<b>35 - 125 PSI</b>	<b>2.4 - 8.6 bar</b>
<b>Water Flow Rate</b>	<b>@ 40 PSI</b>	<b>@ 2.8 bar</b>
Sanitize	9.4 gpm	35.6 lpm
Foam	1.3 gpm	4.9 lpm
<b>Discharge Hose</b>		
ID	3/4 in.	19.1 mm
Length		
Ultimate Foam / Sanitize	50 ft.	15.2 m
LC Foam / Sanitize	40 ft.	12.2 m



### Includes

- Machined polypropylene sanitizer and foamer bodies
- Machined stainless steel sanitizer and foamer bodies (915120SS)
- Stainless steel Y strainer
- Stainless steel mounting enclosure (wall mount models)
- Portable models feature all stainless steel carts.
- Color-coded metering tips (20)
- Metering tip driver
- Quick disconnects to allow single hose to be used for both applications
- Discharge hose, stainless steel ball valve, polypropylene wand and matching nozzle

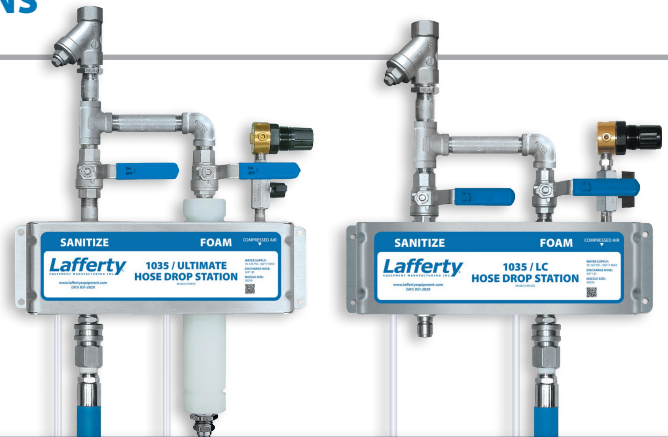

Model #	Description
914120	1035 Sanitize / Ultimate Foam HDS
914122	2-Hose 1035 Sanitize / Ultimate Foam HDS
915120	1035 Sanitize / LC Foam HDS
915122	2-Hose 1035 Sanitize / LC Foam HDS
915120SS	1035SS Sanitize / LCSS Foam HDS
915850	Portable 1035 Sanitize / LC Foam HDS
Foam / Sanitize / Foam Model	
914150	Ultimate / 1035 Sanitize / Ultimate Foam HDS

*Incorporates two Ultimate Foamers with individual air regulators to allow foam application by two workers at the same time and/or of two different chemicals or two different dilution ratios of the same chemical. Requirements and specifications are the same as 914120.*



*Upgrade Option for Sanitize or Foam wands: Stainless Steel Wand upgrade when ordering with unit. Specify upgrade separately for each wand desired. Request item # 536603-X.*

Model #	Description
Options	
807740RQD	40' Red Hose Kit (for LC Hose Drop Station)
807750RQD	50' Red Hose Kit (for Ultimate Hose Drop Station)
336322	Air Gauge Upgrade (installed)
336348	3/4" Water Pressure Gauge Assembly

### Optional Red Hose Kits

- Red sanitizer hoses available for when foaming and sanitizing chemicals are not compatible.

### Includes

- 3/4" (19.1 mm) ID hose (length as noted below)
- Quick disconnect socket
- Stainless steel ball valve
- Wand with matching fan nozzle

# 1035 SANITIZE / RINSE / FOAM HOSE DROP STATIONS

REQUIRES: 35-125 PSI WATER, COMPRESSED AIR

- Lafferty Sanitize/Rinse/Foam Hose Drop Stations are convenient combination systems that apply one chemical as foam and apply a second chemical as a sanitizing spray, and rinse.
- 1035 Sanitizers provide the dilution ratios required for no-rinse applications in food plants.
- Lafferty's unique 4-hole stainless steel rinse nozzle provides a powerful, high performance rinse.
- Ultimate and LC Foamers provide medium volume output for all foaming applications.
- Ultimate Foamers will foam harder-to-foam chemicals, will perform well when water pressure is marginal, and are equipped with a 50 ft. hose. (LC Foamers are equipped with a 40 ft. hose.)
- Quick disconnects allow one hose to be used for foaming and sanitizing.
- Usable foam throw of up to 12 feet, covering up to 500 ft.<sup>2</sup> (46.5 m<sup>2</sup>) in 2½ minutes.
- Portable model features a stainless steel cart that holds two, user-supplied 5-gallon chemical containers. Quick disconnects allow one hose to be used for foaming, rinsing and sanitizing.

## REQUIREMENTS / SPECIFICATIONS

<b>Compressed Air</b>	<b>up to 3 cfm</b>	<b>up to 85 lpm</b>
<b>Water Pressure</b>	<b>35 - 125 PSI</b>	<b>2.4 - 8.6 bar</b>
<b>Water Flow Rate</b>	<b>@ 40 PSI</b>	<b>@ 2.8 bar</b>
Sanitize	9.4 gpm	35.6 lpm
Foam	1.3 gpm	4.9 lpm
Rinse	7.2 gpm	27.3 lpm
<b>Discharge Hoses</b>		
ID	3/4 in.	19.1 mm
Length		
Ultimate Foam/Sanitize and Rinse	50 ft.	15.2 m
LC Foam/Sanitize and Rinse	40 ft.	12.2 m

## Includes

- Machined polypropylene sanitizer and foamer bodies
- Machined stainless steel sanitizer and foamer bodies (SS models)
- Stainless steel Y strainer
- Stainless steel mounting enclosure and stainless steel ball valves
- Portable models feature all stainless steel carts.
- Color-coded metering tips (20)
- Metering tip driver
- Two discharge hose assemblies:
  - Sanitize/Foam: Hose with quick disconnects, stainless steel ball valve, foam wand and matching fan nozzle
  - Rinse: Hose with stainless steel ball valve and Lafferty's powerful 4-hole stainless steel rinse nozzle

## Optional Red Hose Kits

- Red sanitizer hoses available for when foaming and sanitizing chemicals are not compatible.

## Includes

- 3/4" (19.1 mm) ID hose (length as noted below)
- Quick disconnect socket
- Stainless steel ball valve
- Wand with matching fan nozzle



**Upgrade Option for Foam and Sanitize wands this page: Stainless Steel Wand upgrade when ordering with unit. Specify upgrade separately for each wand desired. Request item # 536603-X.**

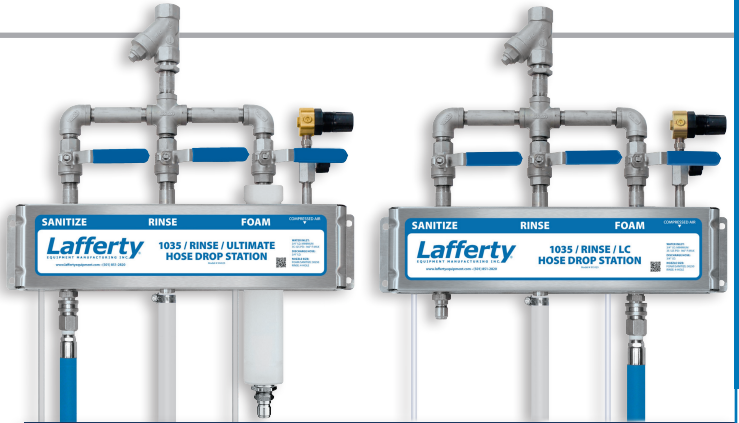

Model #	Description
914121	1-Hose 1035 Sanitize/Rinse/Ultimate Foam HDS
914125	1035 Sanitize/Rinse/Ultimate Foam HDS
914125SS	1035SS Sanitize/Rinse/Ultimate SS Foam HDS
915125	1035 Sanitize/Rinse/LC Foam HDS
915125SS	1035SS Sanitize/Rinse/LCSS Foam HDS
915855	Portable 1035 Sanitize/Rinse/LC Foam HDS
915855SS	Portable 1035 SS Sanitize/Rinse/LCSS Foam HDS

Model #	Description
<b>Options</b>	
807740RQD	40' Red Hose Kit (for LC Hose Drop Station)
807750RQD	50' Red Hose Kit (for Ultimate Hose Drop Station)
336322	Air Gauge Upgrade (installed)
336348	3/4" Water Pressure Gauge Assembly



For portable models, specify round or square jug racks at time of ordering.



# HIGH VOLUME FOAM: SANITIZE / HV FOAM AND SANITIZE / RINSE / HV FOAM HOSE DROP STATIONS

REQUIRES: 35-125 PSI WATER, COMPRESSED AIR

- Lafferty Sanitize / Foam Hose Drop Stations are convenient combination systems that apply one chemical as foam and a second chemical as a sanitizing spray.
- HV Foamers provide high volume output for foaming large surface areas with a usable foam throw distance of up to 15 feet and covering up to 500 ft.<sup>2</sup> (46.5 m<sup>2</sup>) in 1 minute
- 1035 Sanitizers provide dilution ratios required for no-rinse applications in food plants.
- 517 Sanitizers use a medium water flow rate — 5.4 gpm — to provide the dilution ratios required for no-rinse applications in food plants.
- *Rinse* models incorporate a clear water rinse function into the unit.
- Portable model features a stainless steel cart that holds two, user-supplied 5-gallon chemical containers.

## REQUIREMENTS / SPECIFICATIONS

<b>Compressed Air</b>	<b>up to 5 cfm</b>	<b>up to 142 lpm</b>
<b>Water Pressure</b>	<b>35 - 125 PSI</b>	<b>2.4 - 8.6 bar</b>
<b>Water Flow Rate</b>	<b>@ 40 PSI</b>	<b>@ 2.8 bar</b>
1035 Sanitizer	9.4 gpm	35.6 lpm
517 Sanitizer	5.4 gpm	22.4 lpm
Foam	4.0 gpm	15.1 lpm
<b>Discharge Hose</b>		
ID		
Sanitize	3/4 in.	19.1 mm
Foam	1 in.	25.4 mm
Length	50 ft.	15.2 m

### Includes

- Machined polypropylene sanitizer and foamer bodies
- Stainless steel mounting enclosure (wall mount models)
- Stainless steel ball valves
- Color-coded metering tips (20)
- Metering tip driver
- Separate Sanitize and Foam discharge hose assemblies, each with stainless steel ball valve, polypropylene wand and matching nozzle

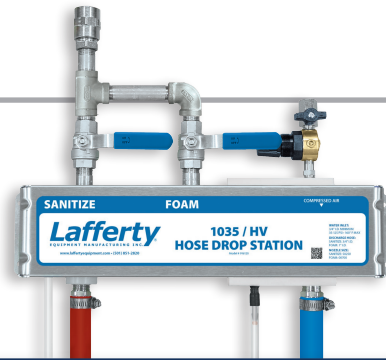

Model #	Description
916120	1035 Sanitize / HV Foam HDS
916125	1035 Sanitize / Rinse/HV Foam HDS
<b>Options</b>	
336322	Air Gauge Upgrade (installed)
336348	3/4" Water Pressure Gauge Assembly



Sanitize discharge hose assembly



Upgrade Option for Sanitize wand: Stainless Steel Wand upgrade when ordering with unit. Request item # 536603-X.



HV Foam discharge hose assembly with fan nozzle (0° nozzle optional for extended foam throw distance)

# Lafferty Conveyor-Mates™

are versatile, conveyor cleaning applicators that are proven to save time and labor. These water-driven venturi systems accurately dilute chemical concentrates to required ratios at the time of use to clean/sanitize conveyor belt surfaces.

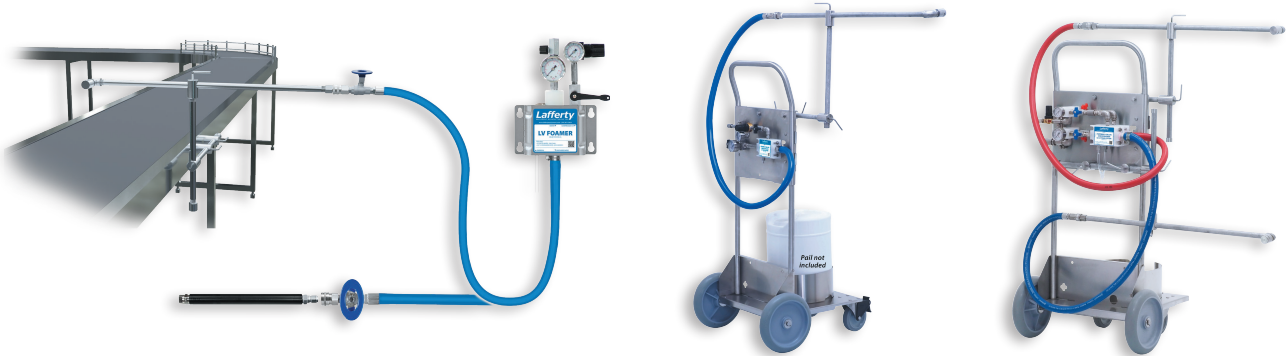

## Choice of Five Applicator Types

Conveyor-Mates are offered with a choice of five applicator types to match precise application requirements.

- 315 Sanitizer – Produces sanitizing spray at a flow rate suitable for no-rinse solutions onto belts up to 48" wide
- Micro Foamer – Produces ultra-low volume, air assisted foam in a narrow fan pattern with a maximum width of 11".
- LV Foamer – Produces low volume, air assisted foam for cleaning/sanitizing belts up to 32" wide
- LC Foamer – Produces moderate volume, air assisted foam for cleaning/sanitizing belts up to 48" wide
- HV Foamer – Produces high volume, air assisted foam for cleaning/sanitizing surfaces from 4' to 10' wide

## Unique Features for Unmatched Adaptability

Conveyor-Mates™ feature adjustable-geometry stainless steel arms and the Lafferty-designed Spreader Nozzles™ that rotate 360° to provide for precise placement and angling of nozzles for optimum results. (Micro Foamer models feature narrow-pattern fan nozzles. HV Foamer models feature a 27" foam bar with Spreader Nozzles™.)



## Two Model Styles

**Mount-in-Place** – The stainless steel spray/foam arm or bar and nozzle assembly can be mounted to the conveyor belt housing or nearby surface and connected to the included sanitizer or foamer mounted nearby. Also includes a quick connect manual spray/foam wand with fan nozzle. (Models # 975910; 975920; 975930; 975940)

**Portable** – Mounted on a stainless steel cart with non-marking wheels, front, swivel casters, and a 5-gallon pail rack

- **One-Arm Portable systems** include one foamer or sanitizer body and a stainless steel spray/foam arm and nozzle assembly. (Model # 975911; 975921; 975931)
- **Two-Arm Portable systems** feature two foam/spray arm and nozzle assemblies and two foamer/sanitizer bodies to match that operate independently for one-side-only or two-side application on conveyors. (Models # 975912; 975915; 975922; 975932)

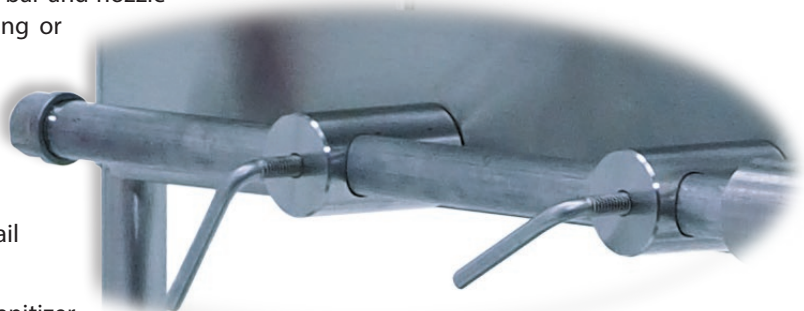

Mounting brackets secure the spray/foam arm and nozzle assembly to the portable cart or flat surfaces for mounting in place. L-bolts with the brackets allow the arms to be extended precisely as the user desires.

Complete details on next three pages (Catalog 1, pages 24-26)

# Conveyor-Mate™

## Features and Specifications

- Industrial-strength design includes machined stainless steel and polypropylene components that ensure durability and years of outstanding performance in the toughest environments.
- Fully-adjustable foam/spray arms accommodate many conveyor belt positions — horizontal, vertical, angled, side-by-side, etc.
- Choice of one-arm, two-arm and foam bar systems to match application requirements. (Two-arm systems available only as portable models.)
- Arms can run independently or simultaneously to clean/sanitize one or both sides of a conveyor belt
- Nozzles can be rotated 360° to project foam/spray at any angle for precision targeting of coverage
- Unique Spreader Nozzles™ (most models) project a wide fan pattern — up to 48" wide — with coverage width adjustable based on angle and distance to the belt surface. (See *Quick Comparison Guide*, next page.)
- The Micro Foam model (975915) nozzles project a narrow fan pattern to cover a maximum width of 11 inches.
- The HV Foam model (975940) with foam bar provides coverage from 4' to 10' wide when mounted 36" above the belt surface.
- Chemical dilution is controlled by precision metering tips
- Dilution ratio for each foam/spray arm is set independently
- Pressure gauges eliminate guessing, reduce set-up time and help with troubleshooting (water gauge for sanitizers; water and air gauges for foamers)

### REQUIREMENTS / SPECIFICATIONS\*

\*for each foam/spray arm

#### Compressed Air

Micro (foamer) up to	<b>0.75 cfm</b>	<b>21.2 lpm</b>
LV (foamer) up to	<b>1.25 cfm</b>	<b>35.4 lpm</b>
LC (foamer) up to	<b>3.00 cfm</b>	<b>85.0 lpm</b>

#### Water Pressure

	<b>35 - 125 PSI</b>	<b>2.4 - 8.6 bar</b>
--	---------------------	----------------------

#### Water Flow Rate

	<b>@ 40 PSI</b>	<b>@ 2.8 bar</b>
Micro (foam)	0.35 gpm	1.3 lpm
LV (foam)	0.65 gpm	2.5 lpm
LC (foam)	1.34 gpm	5.1 lpm
315 Sanitizer	4.00 gpm	15.1 lpm

#### Discharge Hoses (1 for each foam/spray arm)

ID	Micro (foam)	1/2 inch	12.7 mm
	LV and LC (foam)	3/4 inch	19.1 mm
	315 Sanitizer	1/2 inch	12.7 mm
Length		5 ft.	1.5 m

### SELECTION HINT:

## HOW WIDE IS YOUR CONVEYOR BELT?

Conveyor-Mate™	Max. Coverage Width
Micro Foamer	11"
LV Foamer	32"
LC Foamer	48"
315 Sanitizer	48"+
HV Foamer	4' to 10'

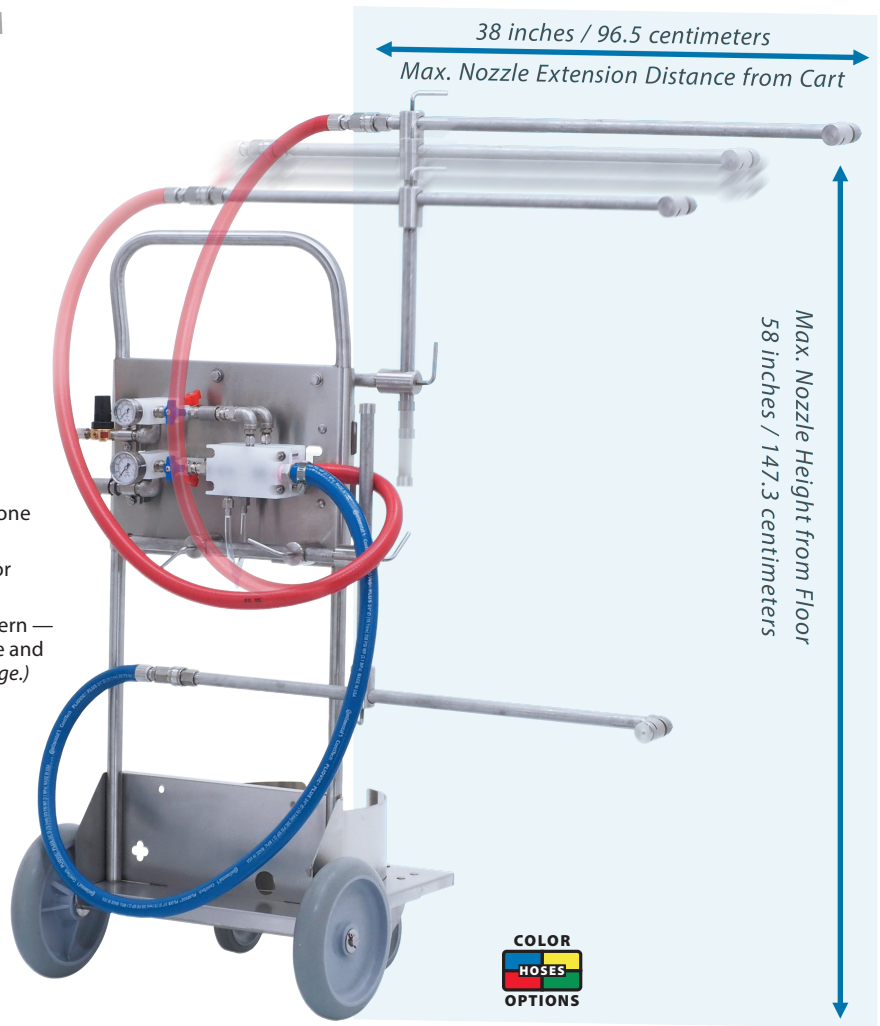

▲ Two arm Conveyor-Mate™ System (available as foam or spray sanitizer applicator)



**Mount-in-Place, one arm Conveyor-Mate™ System** (available as foam or spray sanitizer applicator) – These systems include a hose-end ball valve with quick disconnect socket to allow connecting the hose to a foam or spray wand for manual cleaning/sanitizing.





## CONVEYOR-MATE™ FOAMERS

REQUIRES: 35-125 PSI WATER, CHEMICAL CONCENTRATE, COMPRESSED AIR

- Foamer models project rich, clinging foam, which increases chemical contact time and effectiveness
- Foaming expands the chemical and provides visual assurance of coverage that discourages over-application
- Adjustable foam consistency (wet/dry)
- Low Volume output reduces water and chemical waste
- LV and LC models include Spreader Nozzles™ for wide coverage
- Micro Foam model 975915 includes 6540 fan nozzles for more narrow, precision coverage



Micro Foam Conveyor-Mate™ nozzle assembly ▶

Model #	Description
<b>Portable Two Arm Systems</b>	
975915	Portable 5 Gallon Conveyor-Mate™ Micro / Micro Foam System
975922	Portable 5 Gallon Conveyor-Mate™ LV/LV Foam System
975932	Portable 5 Gallon Conveyor-Mate™ LC/LC Foam System
<b>Portable One Arm Systems</b>	
975921	Portable 5 Gallon Conveyor-Mate™ LV Foam System
975931	Portable 5 Gallon Conveyor-Mate™ LC Foam System
<b>Mount-In-Place One Arm Systems</b>	
975920	Conveyor-Mate™ LV Foam System
975930	Conveyor-Mate™ LC Foam System

### Conveyor-Mate™ Systems Include:

- Easy-to-read pressure gauges (except #975910)
  - Incoming water gauge
  - Air gauge (foamers only)
- Foam/spray arms with quick connects, stainless steel extenders, and stainless steel nozzles:
  - Spreader Nozzles™ (except Micro Foamer #975915)
  - 6540 fan nozzles (#975915 only)
- Machined polypropylene foamer/sanitizer body (1 per arm)
- 5' hose – clamps to foamer body; quick connects to arm (1 per arm)
  - Blue hose with first arm and one arm systems
  - Red hose with second arm

- Color-coded ball valve handles match hose colors on two arm systems (black handles for one arm systems)
- 20 color-coded metering tips for setting dilution ratios (1 set per arm)

### Portable Carts Include:

- All stainless steel 4-wheel cart
- 5 gallon round jug rack (optional square rack)
- Non-marking tires
- Rear stainless steel axel
- Front stainless steel swivel casters with brakes

### Mount-In-Place Models Include:

- Quick connect manual applicator wand with fan nozzle

## CONVEYOR-MATE™ SANITIZERS

REQUIRES: 35-125 PSI WATER, CHEMICAL CONCENTRATE

- 315 Sanitizer accurately dilutes concentrated sanitizers using precision metering tips, and can achieve the lean ratios required for no-rinse applications in food plants
- Projects an adjustable, wide spray pattern.



◀ One arm Conveyor-Mate™ System

Model #	Description
<b>Portable Two Arm System</b>	
975912	Portable 5 Gallon Conveyor-Mate™ 315 / 315 Sanitizer System
<b>Portable One Arm System</b>	
975911	Portable 5 Gallon Conveyor-Mate™ 315 Sanitizer System
<b>Mount-In-Place One Arm System</b>	
975910	Conveyor-Mate™ 315 Sanitizer System

### Conveyor-Mate™ Quick Comparison Guide

TYPE	Water Flow	Compressed Air	Max. Coverage Width
Micro Foamer	0.35 GPM @ 50 PSI	up to 0.75 CFM	11"
LV Foamer	0.65 GPM @ 40 PSI	up to 1.25 CFM	32"
LC Foamer	1.34 GPM @ 40 PSI	up to 3.00 CFM	48"
315 Sanitizer	4.00 GPM @ 40 PSI	N/A	48"+
HV Foamer	4.00 GPM @ 40 PSI	up to 5.00 CFM	4' to 10'

Conveyor-Mate™ HV Foam System with foam bar (next page) ▶

## CONVEYOR-MATE™ HV FOAM SYSTEM

REQUIRES: 35-125 PSI WATER, COMPRESSED AIR

- The Conveyor-Mate™ HV Foam System is specialized for Clean-In-Place foaming on to conveyor belts up to 120" wide and can also be used as a manual foamer.
- HV Foamer accurately dilutes chemical concentrate on demand using precision metering tips
- Accommodates many conveyor belt positions — horizontal, vertical, angled, side-by-side, etc.
- The stainless steel foam bar features two Spreader Nozzles™ that can be rotated to focus coverage over a narrower area or maximize coverage.
- Coverage width adjustable from 4' to 10' at 3 ft. distance.
- Foamer discharge hose quick connects to the foam bar for CIP cleaning or the hand-held wand for manual foaming
- For manual foaming, HV Foamers provide high volume output for foaming large surface areas with a usable foam throw distance of up to 15 feet and covering up to 500 ft.<sup>2</sup> (46.5 m<sup>2</sup>) in 1 minute with fan pattern nozzle.
- Zero degree nozzle for up to 25' range
- Adjustable foam consistency (wet/dry)

### REQUIREMENTS / SPECIFICATIONS

<b>Compressed Air</b>	<b>up to 5 cfm</b>	<b>up to 142 lpm</b>
<b>Water Pressure</b>	<b>35 - 125 PSI</b>	<b>2.4 - 8.6 bar</b>
<b>Water Flow Rate</b>	<b>@ 40 PSI</b>	<b>@ 2.8 bar</b>
HV Foamer	4.0 gpm	15.1 lpm
<b>Discharge Hose</b>		
ID		
Foam	1 in.	25.4 mm
Length	50 ft.	15.2 m

### Includes

- Machined polypropylene HV foamer body
- Stainless steel mounting bracket for foamer
- Stainless steel ball valves
- 50' discharge hose with stainless steel ball valve and quick disconnect socket
- Quick disconnect stainless steel foam bar with Spreader Nozzles™
- Quick disconnect foam wand with fan and zero degree nozzles
- Color-coded metering tips (20)
- Metering tip driver

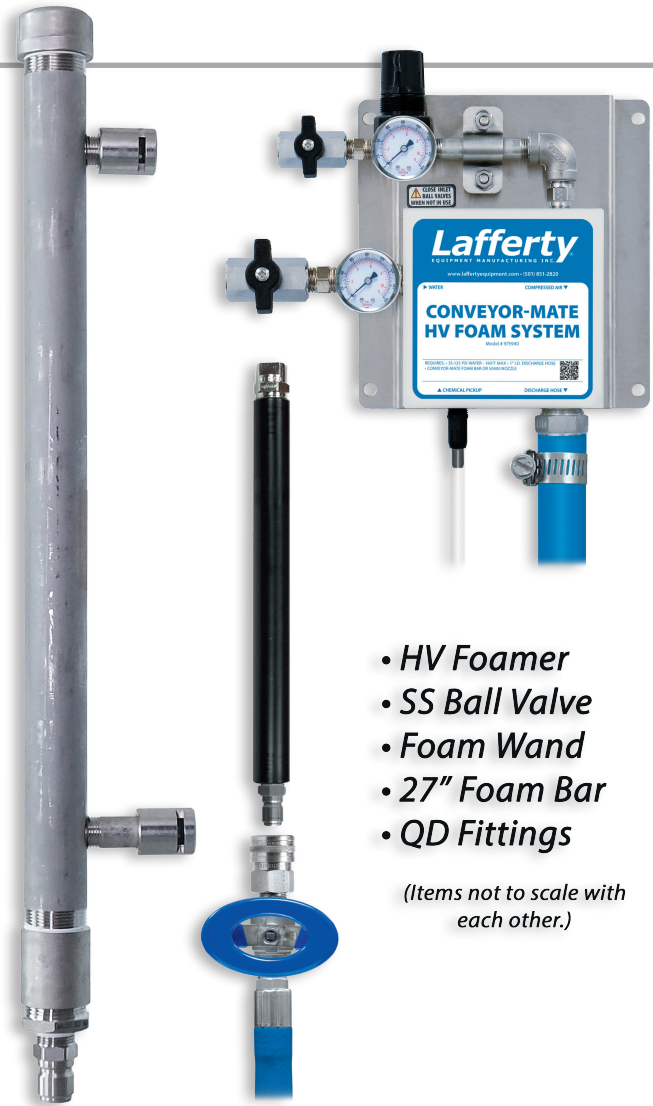

- HV Foamer
- SS Ball Valve
- Foam Wand
- 27" Foam Bar
- QD Fittings

*(Items not to scale with each other.)*

Model #	Description
975940	Conveyor-Mate HV Foam System

## ACCESSORIES

In addition to supplying parts for all Lafferty equipment, Lafferty offers a range of convenient accessories to complement its wide range of chemical application equipment.

Stainless steel jug racks and hose racks can be used with many products, while Drum Sticks and Tote Sticks offer a convenient way to draw chemical from bulk containers. A water pressure / flow test kit provides guidance for equipment selection and when troubleshooting.

## STAINLESS STEEL JUG RACKS

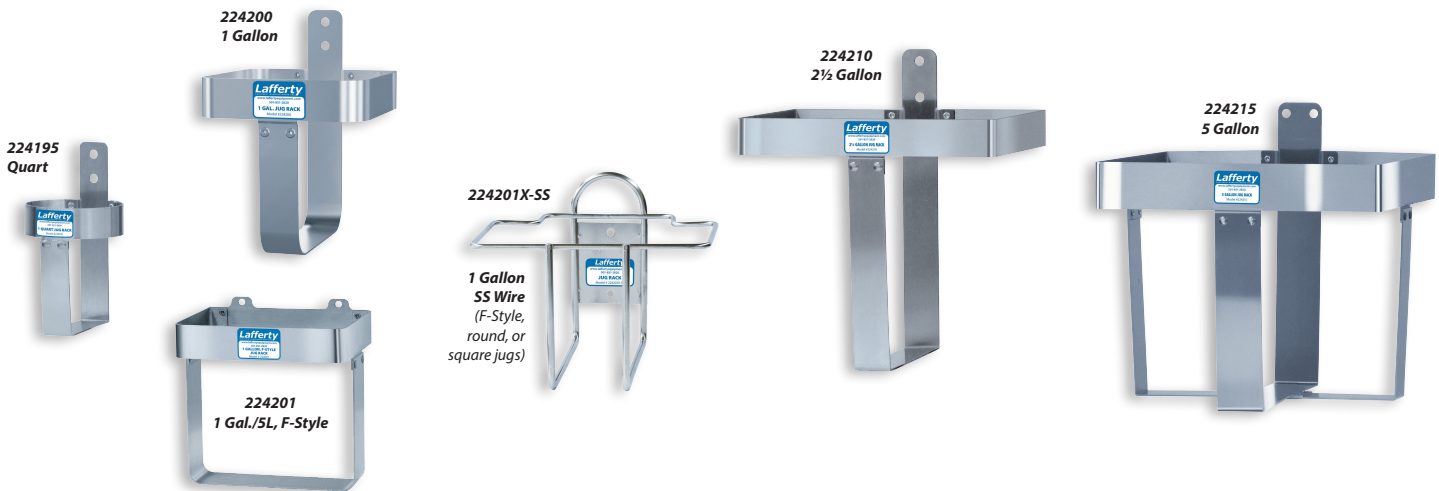

### DIMENSIONS

Model #		Diameter or Width x Depth	
224195	Quart	3 7/8 in. ID	9.8 cm ID
224200	1 Gal. Round/Sq.	6 1/2 x 6 3/8 in.	16.5 x 16.2 cm
224200-L	1 Gal. Rnd./Sq., Locking	6 1/2 x 6 3/8 in.	16.5 x 16.2 cm
224201	1 Gal./5L R'tangle, F-Style	7 5/8 x 5 7/8 in.	19.4 x 14.9 cm
224201X-SS	1 Gal. Wire, Rnd./Sq./F	8 x 6 3/8 in.	22.9 x 22.9 cm
224210	2 1/2 Gal.	10 5/8 x 8 1/2 in.	27.0 x 21.6 cm
224214	5 Gal. Rnd./Sq., Locking	13 x 12 6/8 in.	33.0 x 32.4 cm
224215	5 Gal. Rnd./Sq.	13 x 12 6/8 in.	33.0 x 32.4 cm

Model #	Description
224195	Jug Rack, SS, 1 Quart
224200	Jug Rack, SS, 1 Gallon Round/Square
224200-L	Jug Rack, SS, 1 Gallon Round/Square, Locking
224201	Jug Rack, SS, 1 Gallon/5 Litre Rectangular, F-Style
224201X-SS	Jug Rack, 1 Gallon SS Wire (Round/Square/F-Style)
224210	Jug Rack, SS, 2 1/2 Gallon
224214	Jug Rack, SS, 5 Gallon Round/Square, Locking
224215	Jug Rack, SS, 5 Gallon Round/Square

## LOCKABLE

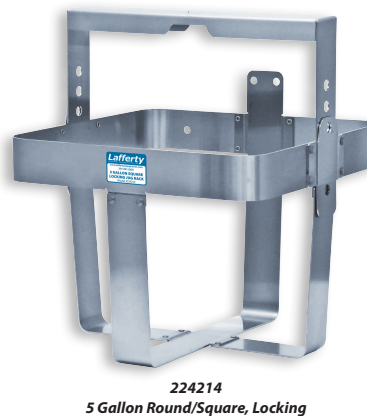



## STAINLESS STEEL HOSE RACKS

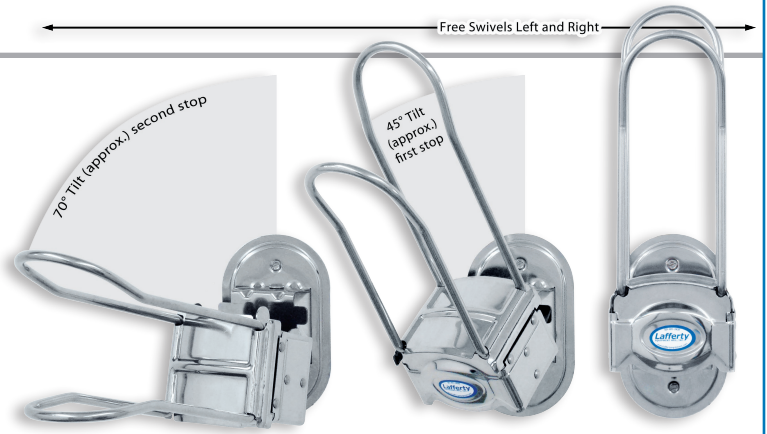

### HOSE CARRYING CAPACITY

Model #		Inside Diameter x Length	
224140	Strap	1/2 in. ID up to 75 ft. (+/-)	12.7 mm ID x 22.9 m (+/-)
224142	Strap, L	3/4 in. ID up to 75 ft. (+/-)	19.1 mm ID x 22.9 m (+/-)
224145	Small	3/4 in. ID up to 50 ft. (+/-)	19.1 mm ID x 15.4 m (+/-)
224150	Large	1 in. ID up to 75 ft. (+/-)	25.4 mm x 22.9 m (+/-)
224160	Tilt	3/4 in. ID up to 100 ft. (+/-)	19.1 mm ID x 30.5+ m (+/-)

Model #	Description
224140	Hose Strap, SS
224142	Hose Strap, SS, Large
224145	Hose Rack, SS, Small
224150	Hose Rack, SS, Large
224160	Hose Rack, SS, Large Tilt

## STAINLESS STEEL HOSE REELS

- This retractable reel features a full-port swivel that allows unrestricted foam output. Other reels may have ports with narrowed openings through the swivel, which compresses the foam, resulting in watery, inferior foam output.
- Use with confidence with a wide range of Lafferty sprayers/sanitizers and foamers that require 1/2" or 3/4" ID hose (*Compatible model groups listed below.*)\*

### FEATURES

- Stainless steel construction and a heavy-duty steel base ensure strength, safety, corrosion resistance, and durability
- Electro-Polished Stainless Steel finish
- Non-Corrosive Stainless Steel Fluid Path Featuring Stainless Steel Swivel
- Auto Rewind via a non-corrosive stainless steel cartridge-style spring motor easily wraps, stores and protects hose
- Adjustable hose stop prevents full hose retraction and allows for quick, easy access to hose-end tools
- Guide arm adjusts to wall, floor and overhead positions
- Pinch-proof, four-way, guide-arm rollers allow the hose to be pulled from the reel in any direction

### REQUIREMENTS / SPECIFICATIONS

<b>Water Pressure</b>	<b>up to 150 PSI</b>	<b>10.3 bar</b>
<b>Discharge Hose ID</b>	<b>either</b>	
	1/2 in.	12.7 mm
	3/4 in.	19.1 mm

### Includes:

- 6' Lafferty-specified jumper hose (assures compatibility with Lafferty foamers and spray applicators)
- Heavy Gauge Steel/Stainless Steel Base and Support Post
- Stainless Steel Rollers
- Factory-Matched Cartridge-Style Spring Motor
- Multi-Position Lock Ratchet Secures Hose At Desired Length
- Rolled Edges and Ribbed Discs Provide Strength and Safety
- Leading 2-Year Manufacturer's Limited Warranty

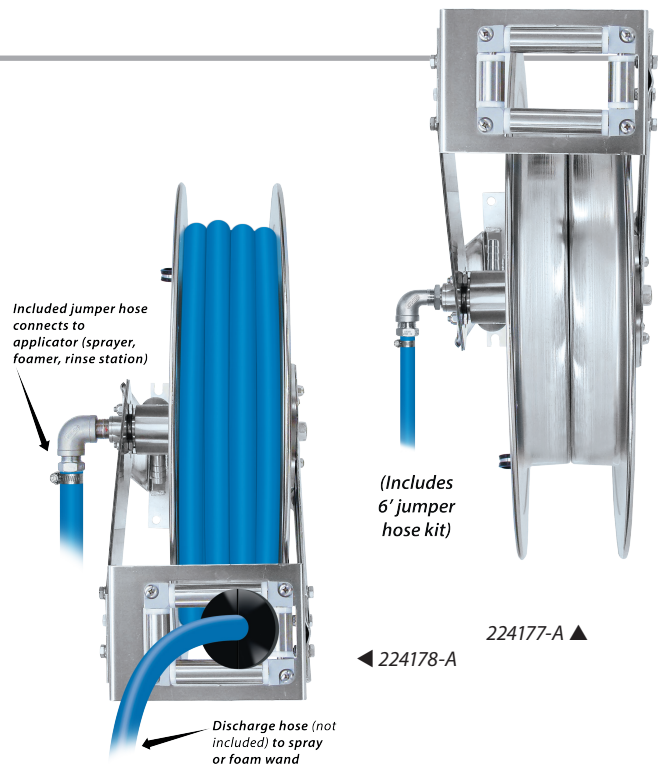

Model #	Description
224177-A <sup>†</sup>	Hose Reel, SS, 1/2" x 50', 150 PSI, With Jumper Hose Kit
224178-A <sup>†</sup>	Hose Reel, SS, 3/4" x 50', 150 PSI, With Jumper Hose Kit

<sup>†</sup>All six weeks production time. Discharge hose and applicator wand not included.

## BACKFLOW PREVENTERS

- Designed for use on non-health-hazard, continuous pressure, point-of-use applications for protection against back siphonage and back pressure
- When installed upstream of a water-driven foamer or sprayer this part will prevent chemical solution and/or compressed air from backing up into the water source in the event of reverse suction (power failure, improper operation, failure to close inlet ball valves, etc.)
- Discharge vent can be plumbed to direct the discharge to an appropriate drainage area.
- May be mounted horizontally or vertically

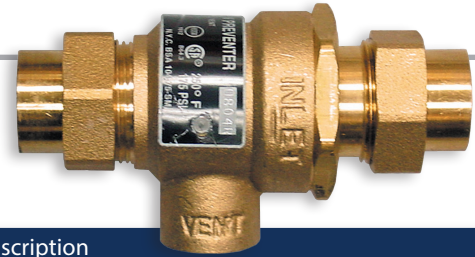

Model #	Description
270298	1/2" (Watts 9DM2) Backflow Preventer
270299	3/4" (Watts 9DM3) Backflow Preventer

## WATER PRESSURE/FLOW TEST KIT

- Provides quick confirmation of available water pressure and water flow at the equipment water inlet
- Connects to standard male garden hose fitting
- Use to determine equipment needed for existing setup or a new facility
- Also for use mounted in line with installed equipment to determine operational water pressure
- Troubleshoot existing setup
- Features three flow restrictors for testing standard flow, medium flow and high flow applicators

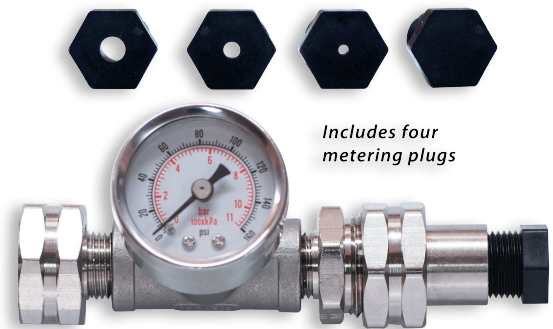

Includes four metering plugs

### REQUIREMENTS / SPECIFICATIONS

<b>Water Pressure Max.</b>	160 PSI	11 bar
<b>Water Flow Rate</b>	@ 40 PSI	@ 2.8 bar
Small restrictor	1 gpm	3.8 lpm
Medium restrictor	4 gpm	15.1 lpm
Large restrictor	9 gpm	34.1 lpm

Model #	Description
336340	Water Pressure / Flow Test Kit

## CHEMICAL DISPENSING ACCESSORIES:

### SAFE FLOW™ JUG OR PAIL LIDS AND PAIL STICKS

- Safe and Convenient — Prevents splashing, reduces odor, and allows for quick replacement of chemical concentrate.
- **Jug / Pail Lids:** Machined polypropylene lids threaded to fit 1 gallon jugs and the pull-up spout of many 5 gallon pails.
- **Jug Lid** includes 1' of suction tubing. (Model 709101-R fits Rieke FLEXSPOUT® closures.) **Slip Stick** includes a sliding Jug Lid and fits containers up to 21" deep.
- All models shown include a hose barb that attaches directly to any 1/4" suction tube of a Lafferty chemical applicator or dispenser.
- **Pail Sticks:** Polypropylene sticks with sliding collars, threaded to fit 3/4" container lid knockouts.
- **Model 709105** includes a 16" Pail Stick and 5 gallon pail with lid.

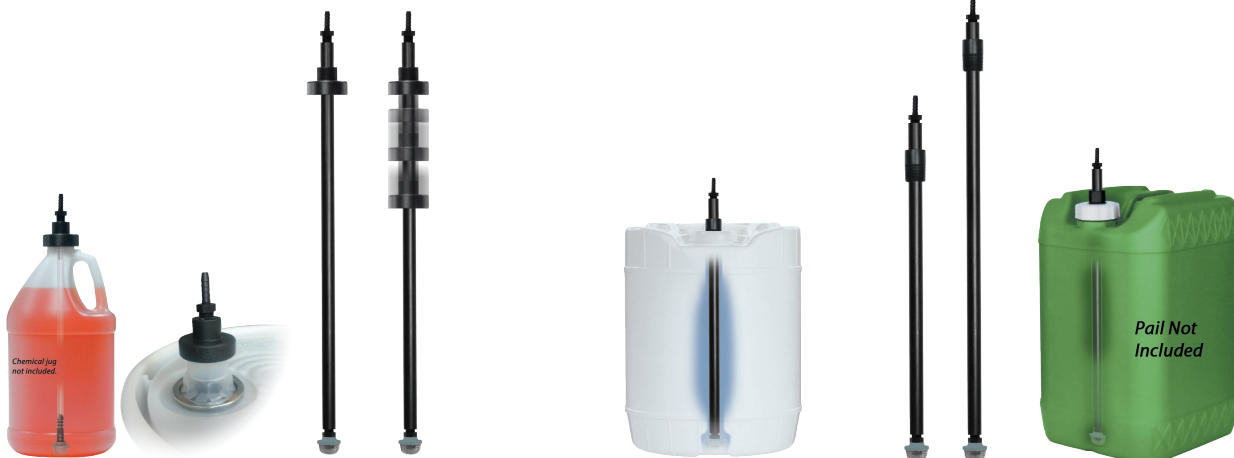

# 709101 (various models)  
1 Gallon Safe Flow Lid w/  
Flexible Tube & Strainer

# 491610 - 5 Gallon  
Safe Flow Lid w/ Rigid  
Tube & Strainer

# 709105 - 5 Gallon Pail  
with Suction Stem

Safe Flow Pail Sticks  
# 491617 - 16" (above, left)  
# 491622 - 21" (above, right)



**LAFFERTY DRUM STICKS™ AND TOTE STICKS™** are chemical pick-up assemblies for use with pump-operated or venturi systems to draw chemical concentrates or diluted chemical solution directly from a drum, tote or holding tank.

Choice of seal material for optimum chemical resistance.

Choice of lengths with custom lengths available.

## DRUM STICK / TOTE STICK

- Chemical/acid resistant polypropylene construction
- Connects to chemical pick-up tubes fitted to any venturi applicator or chemical pumping system
- Drum Bung Adaptor, machined to fit either coarse or fine-threaded bung holes, and Tote Stick Cover, for larger openings on totes and other bulk containers, keep trash out of chemical and allow easy depth adjustment of the Drum or Tote Stick.
- Rigid pipe overcomes problems common with flexible tubing
- Hastelloy strainer easily accessible for cleaning
- Choice of Viton or EPDM seals

### SPECIFICATIONS

#### Polypropylene extension pipe

ID	3/4 in.	19.1 mm
Lengths:	Pipe Length	Inside Drum/Tote
33" Drum Stick	33 in. / 0.83 m	35 in. / 0.89 m
48" Drum Stick	48 in. / 1.22 m	50 in. / 1.27 m
54" Drum Stick	54 in. / 1.37 m	56 in. / 1.42 m
33" Tote Stick	33 in. / 0.8 m	36 in. / 0.91 m
48" Tote Stick	48 in. / 1.22 m	51 in. / 1.29 m
54" Tote Stick	54 in. / 1.37 m	57 in. / 1.45 m

#### Includes

- Machined polypropylene Drum Bung Adaptor with coarse and fine threads or 11" x 11" polypropylene Tote Stick Cover
- Four polypropylene hose barbs:
 

1/4 in.	6.3 mm
3/8 in.	9.5 mm
1/2 in.	12.7 mm
3/4 in.	19.0 mm
- Polypropylene chemical check valve
- Hastelloy chemical strainer

**\*4-Way Drum Stick**  
(can be used only with Mixing Stations or venturi units with check valve #491402 or #491401)

Model #	Description
491643	Drum Stick, 33" (Viton seals)
491643-E	Drum Stick, 33" (EPDM seals)
491644	4-Way Drum Stick, 33" (Viton seals)*
491644-E	4-Way Drum Stick, 33" (EPDM seals)*
491648	Drum Stick, 48" (Viton seals)
491648-E	Drum Stick, 48" (EPDM seals)
491649	4-Way Drum Stick, 48" (Viton seals)*
491645	Drum Stick, 54" (Viton seals)
491645-E	Drum Stick, 54" (EPDM seals)
491653	Tote Stick, 33" (Viton seals)
494653-E	Tote Stick, 33" (EPDM seals)
491654	Tote Stick, 48" (Viton seals)
491654-E	Tote Stick, 48" (EPDM seals)
491656	Tote Stick, 54" (Viton seals)
491656-E	Tote Stick, 54" (EPDM seals)

*Drum/Tote Stick Pipe Length*

*Drum/Tote Stick maximum reach inside drum or tote*

*(Hose Barbs included)*

*Custom lengths available on request*

## METERING TIP DRIVER\*

- Simply the best and easiest way to install or change metering tips across the entire Lafferty venturi product lineup.



Model #	Description
443790	Metering Tip Driver

\* One Metering Tip Driver is included in each pack of metering tips enclosed with new venturi applicator orders.



**JANITORIAL AND SUPERMARKET SANITATION EQUIPMENT** – Catalogs 11 and 12

Lafferty Venturi Systems for use with City Water Pressure include a range of Mixing Stations, Spray-Alls and Airless Foamers that are well-suited for janitorial and supermarket sanitation duty. We produce these and others systems with the same dedicated focus on performance, quality, reliability and durability. An overview is shown below and on the next two pages. *Details are contained in Catalogs 11 and 12.*



**MIXING STATIONS**

- Push Lever & Ball Valve Mixing Stations
- Drum Mount Mixing Station
- Gemini™ Mixing Stations
- High Volume Mixing Station

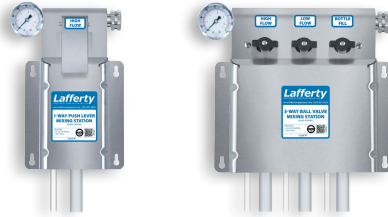

**PRESSURE WASHER / HIGH PRESSURE AIRLESS FOAMERS & SPRAYERS**

**COMBINATION SYSTEMS**

- Spray / Foam and Foam / Rinse / Spray Systems
- WR-1 and WR-2 Spray-All Systems
- Multi-Pet Washing System
- 2-Hose WR-2 Spray-Alls
- WR-3 Spray-Alls (3 chemicals) Foam / Rinse / 2-Way Sanitize

**PUMP UP FOAMERS (1.5 AND 3 GALLON)**

- Pump Up Foamer Pro

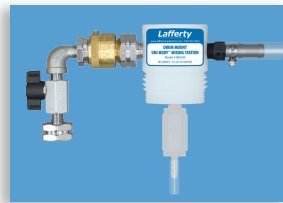

**SPRAYERS AND AIRLESS FOAMERS**

- Compact Sprayers (light and heavy spray models)
- Compact Airless Foamers
- Model 12 – adjustable foam pattern
- Model 25 – up to 12 ft. foam throw
- Airless Foamers (Wall Mount, Portable, Drum Bung)
- Airless Brush Foamers (soft or stiff bristle)



**SMALL AREA CLEANING SYSTEM**

**FEATURES:**

- All stainless steel 4-Wheel Cart
- 12V water pump w/stainless, lockable enclosure
- Re-chargeable battery with 120V charger
- Heavy duty 16-gallon water reservoir



LAFFERTY CATALOG SERIES

• Food & Beverage Processing • Pharmaceutical • Agriculture • General Industrial Applications



1 • Venturi Systems – City Water Pressure

2 • Venturi Systems – Boosted Pressure

3 • Venturi Systems – High Pressure

4 • Compressed Air Operated Systems

5 • Pump Fed Sanitizers, Foamers & Hose Drop Stations

6 • Entryway, Drain & Hand Sanitizing Systems

7 • Foggers and Fogging Systems

Special Applications

8 • Asphalt Release, Acid / Corrosive & Solvent Systems

9 • Chemical Management Systems

10 • Vehicle Wash & Detailing Systems

11 • JanSan / Commercial / Residential Systems

12 • Supermarket / Deli / Small Area Cleaning Systems

